



**Flameproof motors**  
**Moteurs antidéflagrants**  
**Explosionssgeschützte Motoren**  
**Motores antideflagrantes**  
**Motori antideflagranti**

**Aluminium 56 ÷ 80**

---

**Ex d, Ex de • IIB, IIC**



**cemp**



**Atav - Les Ateliers de l'Avre**

---

is a Cemp trademark

**cemp**

---

Flameproof  
Motors



# Flameproof motors

## Moteurs antidéflagrants

### Explosionssgeschützte Motoren

#### Motores antideflagrantes

#### Motori antideflagranti

Aluminium 56 ÷ 80

---

Ex d, Ex de • IIB, IIC

## GB CONTENTS

	Page
<b>1. General informations</b> .....	<b>8</b>
1.1 Series F motors .....	8
1.2 Main characteristics .....	9
1.3 Main options .....	9
<b>2. Design features</b> .....	<b>10</b>
2.1 Mounting arrangements .....	10
2.2 Installation and applications .....	12
2.3 Materials, painting and nameplate .....	13
2.4 Bearing seal and mounting interfaces .....	15
2.5 Terminal box .....	17
<b>3. Connecting diagrams</b> .....	<b>18</b>
3.1 Three-phase motors .....	18
3.2 Single phase motors .....	20
3.3 Self-braking motors .....	21
<b>4. Performance data</b> .....	<b>87</b>
4.1 Three-phase, 1-speed, ventilated motors .....	88
4.2 Three-phase, 1-speed, unventilated motors .....	90
4.3 Three-phase motors, 2 speeds, for general purpose (constant torque) .....	92
4.4 Three-phase motors, 2 speeds, for centrifugal machines (quadratic torque), .....	94
4.5 Three-phase, 1-speed, self-braking motors .....	96
4.6 Motors driven by inverter .....	98
4.7 Single-phase motors, 1 speed, .....	100
<b>5 Overall dimensions</b> .....	<b>103</b>
<b>6 Spare parts</b> .....	<b>117</b>

## F SOMMAIRE

	Page
<b>1 Informations générales</b> .....	<b>24</b>
1.1 Les moteurs de la série F .....	24
1.2 Caractéristiques principales .....	25
1.3 Options principales .....	25
<b>2. Caractéristiques mécaniques</b> .....	<b>26</b>
2.1 Formes de construction .....	26
2.2 Installation et applications .....	28
2.3 Matériaux, peintures et plaque signalétiques .....	29
2.4 Tenue des paliers et interfaces de montage .....	31
2.5 Boîte à bornes .....	33
<b>3. Schémas de branchement</b> .....	<b>34</b>
3.1 Moteurs triphasés .....	34
3.2 Moteurs monophasés .....	36
3.3 Moteurs-freins .....	37
<b>4 Données nominales</b> .....	<b>87</b>
4.1 Moteurs triphasés, 1 vitesse, ventilés .....	88
4.2 Moteurs triphasés, 1 vitesse, non ventilés .....	90
4.3 Moteurs triphasés, 2 vitesses, pour usage général (couple constant) .....	92
4.4 Moteurs triphasés, 2 vitesses, pour machines centrifuges, (couple quadratique) .....	94
4.5 Moteurs-freins triphasés, 1 vitesse .....	96
4.6 Moteurs alimentés par inverseur .....	98
4.7 Moteurs monophasés, 1 vitesse .....	100
<b>5. Dimensions d'encombrement</b> .....	<b>103</b>
<b>6 Pièces détachées</b> .....	<b>117</b>

## D INHALTSVERZEICHNIS

	Seite
<b>1. Allgemeine Informationen</b> .....	<b>40</b>
1.1 Motoren Serie F .....	40
1.2 Hauptmerkmale .....	41
1.3 Hauptausführungen .....	41
<b>2. Mechanische Eigenschaften</b> .....	<b>42</b>
2.1 Bauformen .....	42
2.2 Installation und Anwendungen .....	44
2.3 Material, Lackierung und Typenschild .....	45
2.4 Dichtung der Lager und Montageschnittstellen .....	47
2.5 Klemmkasten .....	49
<b>3. Schaltung</b> .....	<b>50</b>
3.1 Drehstrommotoren .....	50
3.2 Einphasenmotoren .....	52
3.3 Selbstbremsende Motoren .....	53
<b>4. Betriebsdaten</b> .....	<b>87</b>
4.1 Drehstrommotoren, 1 Drehzahl, belüftet .....	88
4.2 Drehstrommotoren, 1 Drehzahl, unbelüftet .....	90
4.3 Drehstrommotoren, 2 Drehzahlen, für allgemeinen Gebrauch (konstantes Gegenmoment), .....	92
4.4 Drehstrommotoren, 2 Drehzahlen, für Zentrifugalmaschinen, (quadratisches Gegenmoment), ..	94
4.5 Selbstbremsende Drehstrommotoren, 1 Drehzahl .....	96
4.6 Durch Frequenzwandler betriebene Motoren .....	98
4.7 Einphasenmotoren, 1 Drehzahl, .....	100
<b>5. Abmessungen</b> .....	<b>103</b>
<b>6. Ersatzteilliste</b> .....	<b>117</b>

# Flameproof motors

GB

# 1. General information

## 1.1 Series F motors

### 1.1 Series F ATEX motors

The motors offered in this catalogue comply with standards concerning equipment and protective systems intended for use in potentially explosive atmospheres, in compliance with European Directive 94/9/EC dated 23/3/94, otherwise known as the ATEX directive.

The ATEX directive states that two different certificates of conformity are to be issued.

One is the "EC Standard type" for the homologation of the prototype and the other is for the "Production Quality Assurance".

The Certificates are issued by the Laboratoire Central des Industries Electriques (L.C.I.E) (Notified Body no. 0081).

The conformity certificate numbers are listed in the performance data.

The production quality Guarantee certificate number is:  
LCIE 00 ATEX Q8007.

**Table 1 A** - The series F ATEX

Version	Frame size [mm]	Output range (2 pole) [kW]	Temperature class (*)	Series	
				IIB	IIC
Single speed, three phase (2, 4, 6, 8 poles)	63 - 80	0,12 - 1,50	T5 / T6	<b>F-BTV</b>	<b>F-CTV</b>
Three-phase, 1-speed, unventilated (2, 4, 6, 8 poles)	56 - 80	0,06 - 0,55	T4	<b>F-BST</b>	<b>F-CST</b>
Two speeds, three phase (2/4, 4/6, 4/8 poles) (constant-torque)	63 - 80	0,25 - 0,75	T4	<b>F-BTV</b>	<b>F-CTV</b>
Two speeds, three phase (2/4, 4/8, 4/6, 6/12 poles) (quadratic-torque)	63 - 80	0,25 - 1,10	T4	<b>F-BTV</b>	<b>F-CTV</b>
Three-phase, 1-speed, with brake (2, 4, 6, 8 pôles)	63 - 80	0,12 - 1,10	T4	<b>F-BTVF</b>	<b>F-CTVF</b>
Single phase, (2, 4, 6 poles)	56 63 - 80	0,06 - 0,08 0,12 - 0,75	T4	<b>F-BM</b> <b>F-BMV</b>	<b>F-CM</b> <b>F-CMV</b>

(\*) For minimum overheating, the temperature class is indicated in chap. 4 (Performance data).

**Table 1 B** - Customizable temperature class (referred to an ambient temperature of 40°C)

Frame size	T5	T6
<b>56 - 80</b>	Same power as T4 (*)	Power lower

(\*) For single and three-phase, 2-speed motors: power lower than T4, unless otherwise specified in chap. 4.1.

## 1.2 Main characteristics

## 1.3 Main options

### 1.2 Main characteristics

---

- Explosion-proof motors according to European standard CENELEC EN 50 014, EN 50 018 and EN 50 019 (for terminal box Ex e).
- The European Standards are known and accepted by most Countries world-wide besides CENELEC (European Committee for Electrotechnical Standardization) member countries.
- Three phase and single phase Squirrel Cage Asynchronous Induction motors.
- Totally enclosed, fan cooled, frame IP55 with Terminal box IP65.
- The motors dimensions comply with IEC 60072 standard.
- Power Supply 400V / 50Hz. Three-phase, 1-speed motors, 2-4-6-8 poles, T4, for sizes between 56 and 80, multi-voltage power supply 380-400-420V/ 50 Hz.
- Class F insulation.
- Noise level (dBA)  
Noise values measured both loadless and at the rated power supply condition are lower than those set forth by the NF 51-119 Standard (IEC 34-9). We can also provide special applications.
- Terminal Box:
  - available both in a flameproof version, or in an increased safety version
  - large size
  - normally installed on the side opposite the feet, can be oriented right- or left-wards
  - frame separation grid
  - rotating by 90° in 4 positions
  - frame separation grid.
- Motor frame:
  - cooling fins
  - removable feet
  - pad for direct frame connection
  - removable through hole flange
  - front and back lip seal (IP55)
  - earthing screw.
- Rotor:
  - in pressure cast aluminium alloy
  - shaft mounting by ring nut
  - dynamic balanced with feather key fully seated
  - insulating paint.
- High protection against corrosion:
  - stainless steel nameplate
  - anticorrosion plated fasteners.
- The following parts are highly resistant to impact:
  - cast aluminium fan cover.
- Low friction dust seals.
- Vibration level:  
the dynamic balancing of the rotors (half spline) allows for a level of residual vibrations in three-phase motors which corresponds to the N degree (normal) according to IEC 34-14.
- The conformity certificates also cover design characteristics that differ from the basic version, such as:
  - modification of the maximum installation altitude
  - modification of the rated voltage and rated frequency
  - power supply from an inverter
  - motor protection through temperature detectors
  - application for operating modes S2 to S9.

GB

### 1.3 Main options

---

- Non-standard voltages and frequencies (maximum voltage 690V).
- Motors with special electrical design.
- Motors suitable for frequency inverter drive.
- Special flanges and shafts.
- Double ended shafts.
- Grade R and S balancing.
- Large motors with special bearings (unidirectional).
- Motors protection IP56 - IP65 - IP66.
- Tropicalised motors (relative humidity level H% including between 90 and 98%).
- Motors with bi-metallic detector thermistors, PTC thermistors or PT100 resistive sensors (a second cable gland is supplied).
- Motors with heaters.
- Motors with rain cap.
- Increased safety "e" terminal box, see chap. 2.5.
- Terminal box with special cable entries.
- Motors without terminal box, with cable output.
- Motors with tachogenerator or encoder.
- Motors for areas classified as zone 21 and zone 22 (Dust).
- Motors for special applications available on request.

## 2. Design features

### 2.1 Mounting arrangements

#### 2.1 Mounting arrangements

The most commonly used mounting arrangements are shown in the table 2 A. Other mounting arrangements are available on request.

Standard motors ordered in basic mounting arrangements (universal mounting arrangements)

IM B3, IM B5 or IM B14 can also be operated in the following different mounting positions:

IM B3 in IM B6, IM B7, IM B8, IM V5 or IM V6,  
IM B5 in IM V1 or IM V3,  
IM B14 in IM V18 or IM V19.

According to the restrictions for explosion-proof electrical machinery it is forbidden that foreign bodies be allowed to fall into the fan cowl.

Therefore vertically mounted shaft down motors are fitted with a protective hood over the fan cowl.

In case of vertical arrangement with shaft end up the protection against foreign bodies must be ensured by the working machine or by a suitable cover.

However, the cooling air access may not be hindered by this cover.

**Table 2 A**

Foot-mounted motor

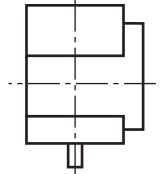
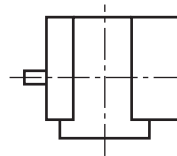

CEI 2-14

B3

V5

IEC 34-7 code I

IM B3

IM V5

IEC 34-7 code II

IM 1001

IM 1011

Flange-mounted motor:  
large flange,  
clearance fixing holes

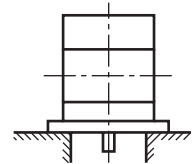
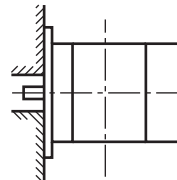

Foot and flange-mounted motor:  
large flange, clearance fixing holes

CEI 2-14

B5

V1

IEC 34-7 code I

IM B5

IM V1

IEC 34-7 code II

IM 3001

IM 3011

Flange-mounted motor:  
small flange,  
tapped fixing holes

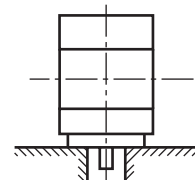
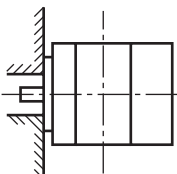

Foot and flange-mounted motor:  
with small flange, tapped fixing holes

CEI 2-14

B14

V18

IEC 34-7 code I

IM B14

IM V18

IEC 34-7 code II

IM 3601

IM 3611



# 2.1

GB

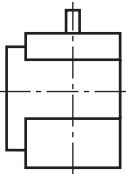

V6  
IM V6  
IM 1031

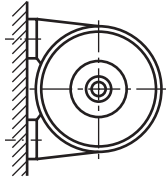

B6  
IM B6  
IM 1051

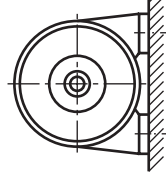

B7  
IM B7  
IM 1061

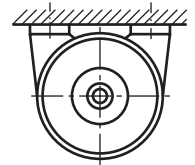

B8  
IM B8  
IM 1071

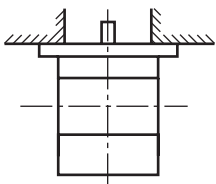

V3  
IM V3  
IM 3031

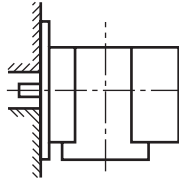

B35  
IM B35  
IM 2001

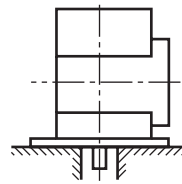

V15  
IM V15  
IM 2011

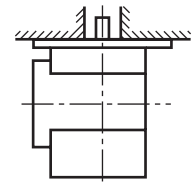

V36  
IM V36  
IM 2031

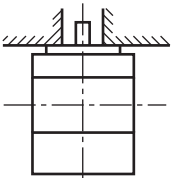

V19  
IM V19  
IM 3631

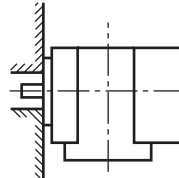

B3/B14  
IM B34  
IM 2101

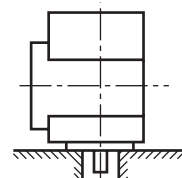

V5/V18  
IM V58  
IM 2111

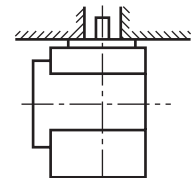

V6/V19  
IM V69  
IM 2131

## 2.2 Installation and application

### 2.2.1 Thermal and environmental specifications

#### 2.2.2 Harsh industrial environments

### 2.2.1 Thermal and environmental specifications

---

#### Operating conditions

Except for some particular notes, the specifications of the motors of chap. 4 (Performance data) correspond to the operating condition S1 (uninterrupted operation according to IEC 34-1). Special requirements for other approved conditions of use can be met.

#### Explosion groups and temperature classes

Except for some particular notes, motors are available in Group IIB or IIC. The standard temperature class with which motors are supplied is T4, unless otherwise specified in chap. 4.1 (Performance data). Motors class T5 or T6 are also available on request.

#### Ambient temperature and altitude

The control of surface temperatures within the limits set forth by the temperature class entails the use at an ambient temperature which should be less than or equal to 40° C and at an altitude lower than or equal to 1000 m (according to NF C 51-111). The minimum ambient temperature for using the standard motors of the choice chart is of -20° C. Further information on operating conditions not complying with these limits is available on request.

#### Winding overheating

The overheating of motor winding described in chap. 4 (Performance data) is less than or equal to 80 K.

#### Thermal limits of the winding insulators

The winding insulators are made with class F materials.

#### Humidity

The standard motors of the choice chart can be used up to a relative humidity of H% = 90.

### 2.2.2 Harsh industrial environments

---

For harsh industrial environments (among which chemical industry, raw materials industry, and energy production), proposes a hardened model according to the German standard VIK (Vereinigung Industrielle Kraft wirtschaft).

The corresponding option, called "VIK", relates to Ex de IIC motors.

Compared to the standard, the construction differences are:

- improved safety Ex e large-sized terminal box, provided with screw studs, with adjustable cable output that prevents having to move the board.
- PTC thermal protection included,
- stainless steel nuts, bolts and nameplate,
- two-layer epoxy resin outside finish, 2 x 40 µm,
- inside finish: insulating paint on rotor and winding coil heads,
- additional nameplate in the terminal box,
- rain cap.

## 2.3 Materials, painting and nameplate

### 2.3.1 Materials and painting

#### 2.3.1 Materials and painting

##### Materials

Table 2 B - Materials of the main components

Frame size	56 - 80
Frame Endshields Terminal box Fan cover	Standard aluminium alloy
Fan	Antistatic composite plastic material or aluminium
Shaft	Acier XC 48
Stator	Rigidly assembled low-loss metal sheets
Winding	Class of insulation F or H
Bolts and screws	Galvanized steel; stainless steel is also available on request

##### Surface treatment specifications

###### Standard finish:

No treatments, natural aluminium-coloured motor.

Recommended for use:

- in damp places or with water vapour
- in chemical or not very aggressive environments
- with motor surface temperatures from -20° C to +130° C.

###### Optional finish:

- Primer:
  - degreasing
  - one phosphating layer of about 20 µm (compatible with any further finish, except for epoxy resin)
- Polyurethane finish
  - degreasing
  - one modified vinyl wash primer layer of about 10 µm
  - one glossy of blue (RAL 5010) two-component polyurethane layer (of about 30 µm)
  - nuts and bolts in stainless steel.

Recommended for use:

- in wet places, with water vapour or with poorly saline air
- in fairly harsh industrial environment with occasional ejection of aggressive chemical products.
- with motor surface temperatures from -20° C to +130° C.

- Epoxy resin finish
  - degreasing
  - one modified vinyl wash primer layer of about 10 µm
  - one glossy of blue (RAL 5010) two-component polyamide epoxy resin (of about 25 µm)
  - stainless steel nuts and bolts.

Recommended for use:

- in wet places, with water vapour or with saline air
- in harsh industrial environment with aggressive chemical products.
- with motor surface temperatures from -20° C to +130° C.

- Special finishes can be provided.

## 2.3

### 2.3.2 Nameplate

#### 2.3.2 Nameplate

##### Identification

Motors are identified by a nameplate with the markings described below:

**Table 2 C** - Markings prescribed by the current regulation

Markings	Meaning
CE	CE mark
Ex	Specific explosion protection related mark
Ex	Symbol of safety equipment meeting a protection class
d	"Flameproof enclosure" protection class
de	"d" motor and "e" terminal box
II	Explosion group
B - C	Enclosure group
T4 - T5 - T6	Ignition temperature class
LCIE N° ...	CE type certificate no

**Table 2 D** - Other markings

Markings	Meaning
ATAV	Commercial mark
CEMP FRANCE NONANCOURT FRANCE	Manufacturer's name and address
Type ...	Motor's commercial reference
N° ./.	Serial no./Year of manufacture
kg ...	Motor's weight
kW ...	Motor's power
Volts ...	Delta voltage / star voltage
Amp ...	Delta current / star current
Cos. ...	Power factor
Hz ...	Rated frequency
min-1 ...	Rpm
S ...	Operating conditions
Cl.	Insulation class
IP	Protection class
°C amb ...	Maximum ambient temperature
Vis: Cl.	Nuts and bolts resistance class

##### Nameplate

The nameplate, made of stainless steel, is secured to the frame with grooved nails.

ATAV Les Ateliers de l'Avre		CE	0081	Ex II2G
Fabriqué par: Cemp France sa F 27320 NONANCOURT				
Type:	N°			
Exd II T	L.C.I.E. ATEX			
IP	Vis/screw Schraube : cl.			
kW				S
Hz				cl.
V±10%				Date:
min <sup>-1</sup>				°C max
A				kg
cos φ				IEC 34-1

**Fig. 2 A** - Nameplate

## 2.4 Bearing seal and mounting interfaces

### 2.4.1 Bearings

#### 2.4.2 Mechanical specifications

### 2.4.1 Bearings

Standard motors are provided with ball bearings with deep and sealed grooves. Bearings on the driving end are locked.

Bearings used:

Frame size (mm)	Bearing, driving end, type	Bearing, non driving end, type
56	6202 ZZ	6200 ZZ
63-71	6203 2RS	6203 2RS
80	6005 2RS	6004 2RS

GB

### 2.4.2 Mechanical specifications

#### Loads applicable on the shaft end

The maximum dynamic loads that can be applied (N) for an operating cycle of L10h = 25,000 hours are as follows:

Table 2 E

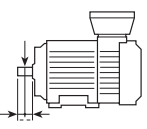
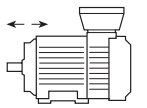
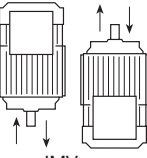
Stress direction	Stress (N)											
	2 poles Frame size			4 poles Frame size			6 poles Frame size			8 poles Frame size		
	56	63-71	80	56	63-71	80	56	63-71	80	56	63-71	80
 IMB... ; IMV...	350	480	510	460	610	650	540	710	740	600	780	820
 IMB...	240	350	370	330	440	470	370	510	540	420	560	590
 IMV...	220	330	330	310	420	430	350	490	500	400	540	550
	250	370	410	340	460	510	400	530	580	440	580	630

## 2.4

### 2.4.3 Special manufactures

#### 2.4.3 Special manufactures

##### Motor mounting interfaces

In addition to the standard mounting arrangements shown in chapter 2.1, motors are also available mounted with pads for anchorage to a pipe or ventilation system.

##### Special flanges

Motors are available with flanges other than standard flanges which comply with NFC 51-120 regulations, with through holes (B5) or threaded holes (B14).

The table below, in addition to the figures given in chapter 5 (Overall dimensions), gives the measurements of the available flanges.

GB

Table 2 F

Frame size	Structural form	Flange	Dimensions [mm]				
			Ø M	Ø N	Ø P	Ø TLB	Ø TTB
56	B5	FF85	85	70	105	7.0	---
	B5	FF115	115	95	140	9.0	---
	B14	FT75	75	60	90	---	M5
63	B5	FF100	100	80	120	7.0	---
	B14	FT65	65	50	85	---	M5
	B5	FF130	130	110	160	9.0	---
	B14	FT85	85	70	105	---	M6
71	B5	FF100	100	80	120	7.0	---
	B14	FT65	65	50	85	---	M5
	B5	FF115	115	95	140	9.0	---
	B14	FT75	75	60	90	---	M5
	B5	FF165	165	130	200	11.0	---
80	B5	FF115	115	95	140	9.0	---
	B5	FF130	130	110	160	9.0	---
	B14	FT85	85	70	105	---	M6
	B5	FF215	215	180	250	13.5	---

## 2.5 Terminal box

### 2.5 Terminal box

#### Wiring with “d” terminal box

- Terminal box is arranged according to the feet (for IM1... or IM2... mounting).

The terminal box axis is normally perpendicular to the laying surface.

Optionally, it can be supplied for “right” or “left” mount according to a front view of the motor, main shaft end side (without surcharge).

Note: the terminal box position can only be changed at the factory.

- Cable output position

In standard executions, the cable output is on the right (looking at the motor from the shaft side).

All other options must be requested at the time of the order using the same reference (upper, lower, left, right, front and rear cable output).

- “d” cable gland

In “Ex d” motors, the cable gland aids the flameproof enclosure closing.

The user MUST choose a cable with a diameter on the sealing membrane side corresponding to the cable gland specification, as well as use a device for hooking the cable on the cable external diameter side.

The motors are supplied with an Ex d cable gland (optional) with cable hook. On the sealing membrane side, the cable must have a diameter of  $11 \pm 0.5$  mm.

#### Options for cable gland “d”

- terminal box supplied without cable gland, with threaded hole ISO M
- gasket  $\varnothing$  9 or 13 mm for cable gland
- additional cable gland (standard model) or additional hole
- cable gland with shielding extension
- cable gland for armoured cable or special cable gland.

#### Options for terminal box “e”

- Increased safety Ex e terminal box:
- available for ventilated three-phase motors with 63 to 80 HA
- IP55 (IP65 optional); maximum voltage 690V, waterproof connection system, removable between terminal box and frame supplied with an Ex e cable gland (optional) for a non-armoured cable with 7.5 to 13 mm diameter (M20 ISO). Cable gland option: contact us for further information.

#### Other options

- Motors without terminal board.
- Motor with cable output:
  - available for the three-phase series
  - power supply cable (4 or 7 wires) connected at the factory
  - small overall dimensions, thanks to the elimination of the terminal box on the ventilated three-phase motors
  - dimensions and further features: contact us for further information.
- Manual control on/off switch built in the terminal box (only HA 63-71-80).

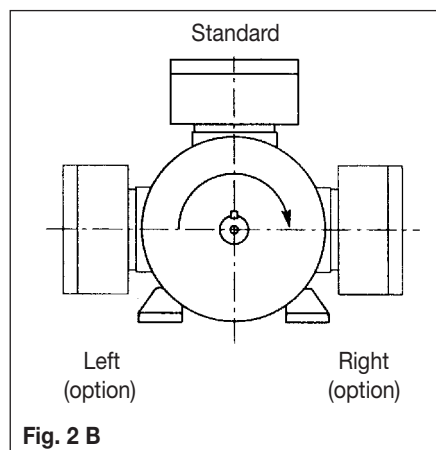

Fig. 2 B

## 3. Connecting diagrams

### 3.1 Three-phase motors

#### 3.1 Three-phase motors

The winding of standard motors can be connected together to form two different connections:

- star connection
- delta connection

##### Star connection

Connecting together the W2, U2, V2 terminals (star point) and connecting to the mains the U1, V1, W1 terminals a star connection is obtained.

The phase current  $I_{ph}$  and the phase voltage  $U_{ph}$  are the following:

$$I_{ph} = I_n$$

$$U_{ph} = U_n / \sqrt{3}$$

where  $I_n$  the line current and  $U_n$  is the line voltage.

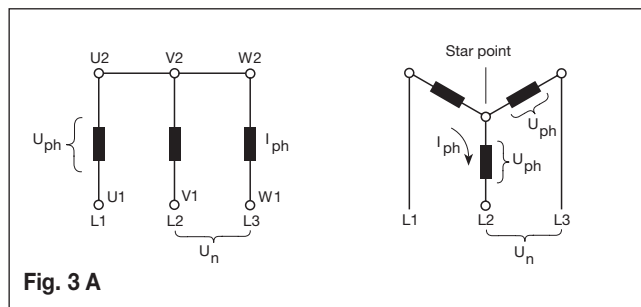

##### Delta connection

Connecting the end of each winding to the beginning of the next winding a delta connection is obtained.

The phase current  $I_{ph}$  and the phase voltage  $U_{ph}$  are the following:

$$I_{ph} = I_n / \sqrt{3}$$

$$U_{ph} = U_n$$

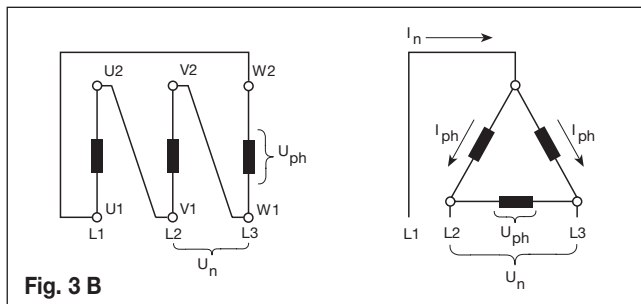

##### Star - Delta starting

The star-delta starting is an easy way to reduce the starting current and starting torque.

Motors can be started with the star-delta starting method whenever the supply voltage correspond to the rated voltage of the motors in delta connections.

##### Two speed motors

Standard two speed motors are designed for only one rated voltage and for direct starting.

When the speed ratio is 1/2 the standard motors have one winding (Dahlander connection). For the other ratios motors have two different windings.



**Connection for single speed motors:**

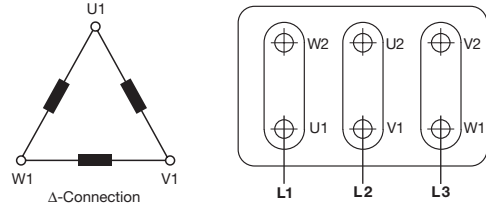
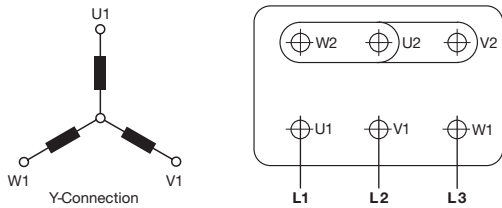

Number of pole: 2, 4, 6, 8 .....  
 Synchronous speed at 50 Hz: 3000, 1500, 1000, 750 .....

**Two separate windings for two speed motors:**

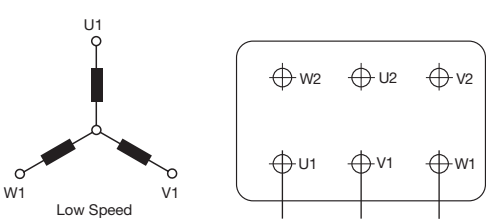
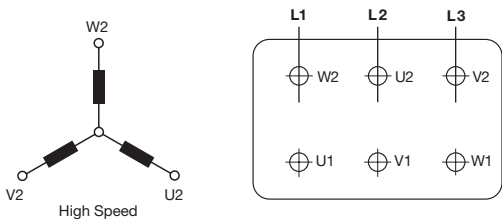

Number of pole: 2/6, 2/8, 4/6, 6/8  
 Synchronous speed at 50 Hz: 3000/1000, 3000/750, 1500/1000, 1000/750.

**Dahlander system for two speed motors, constant torque:**

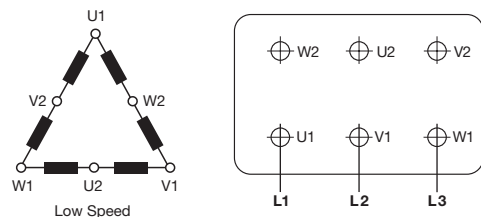
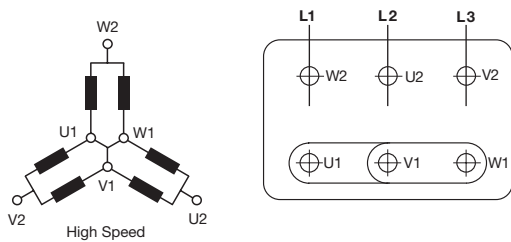

Number of pole: 2/4, 4/8  
 Synchronous speed at 50 Hz: 3000/1500, 1500/750.

**Dahlander system for two speed motors, quadratic torque:**

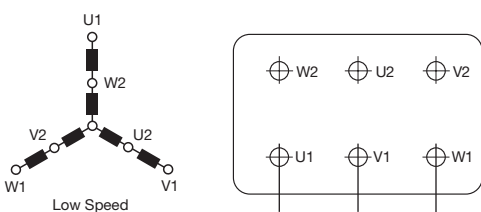
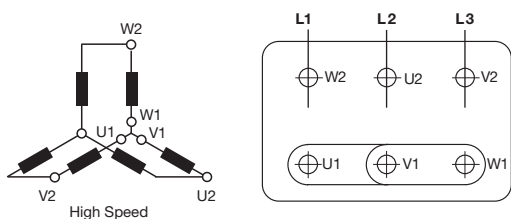

Number of pole: 2/4, 4/8  
 Synchronous speed at 50 Hz: 3000/1500, 1500/750.

**Fig. 3 C - Three phase motors connecting diagrams.**

## 3.2 Single phase motors

### 3.2 Single phase motors

GB

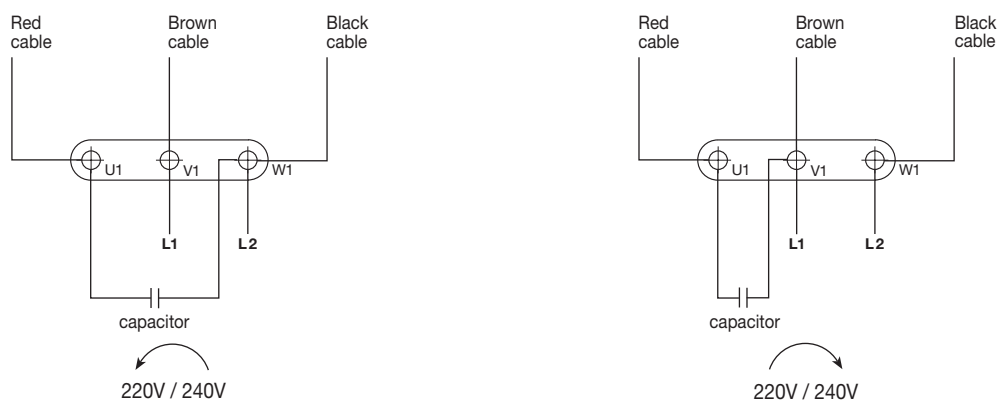

Fig. 3 D - Single-phase motor wiring diagrams F56

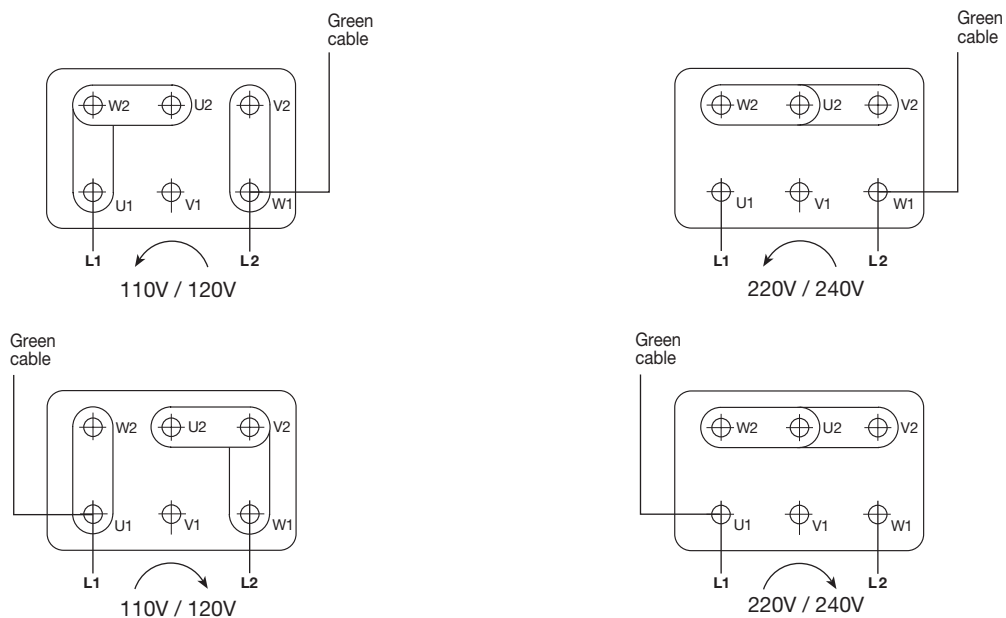

Fig. 3 E - Single-phase motor wiring diagrams F63-80

### 3.3 Self-braking motors - Groups IIB and IIC (BTVF and CTVF)

#### 3.3.1 Brake power supply

#### 3.3.2 Brake operating limits

#### 3.3.3 Adjustments

### 3.3.1 Brake power supply

Figures show the various power supply diagrams of the brake, with or without the "reduced response time" option.

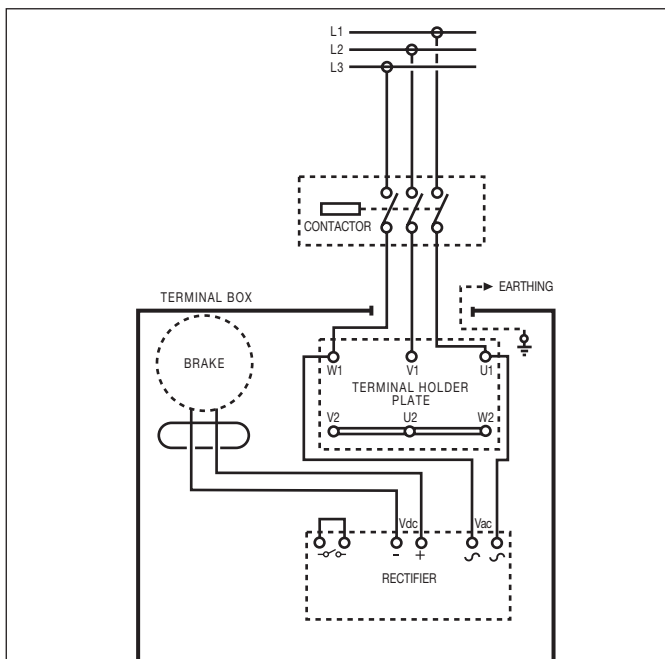

**Fig. 3 F** - Standard response time  
Brake power supply parallel with the motor power supply

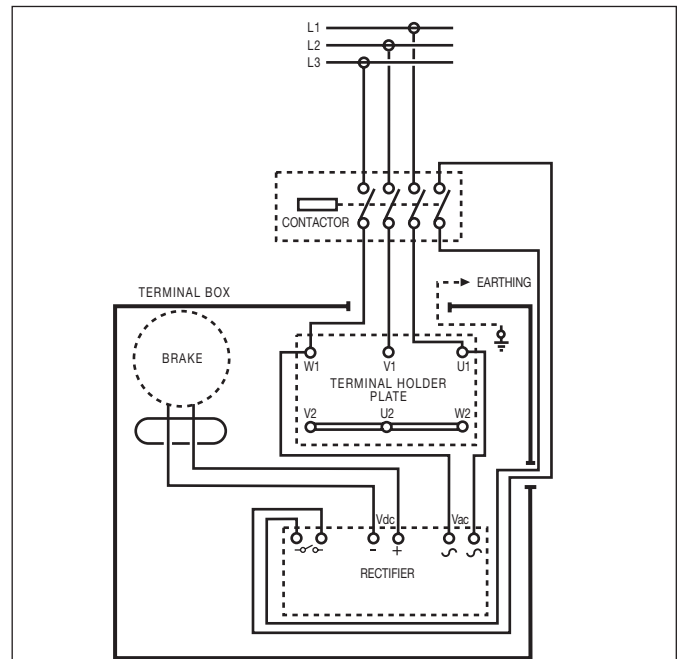

**Fig. 3 G** - Reduced response time  
Brake power supply parallel with the motor power supply

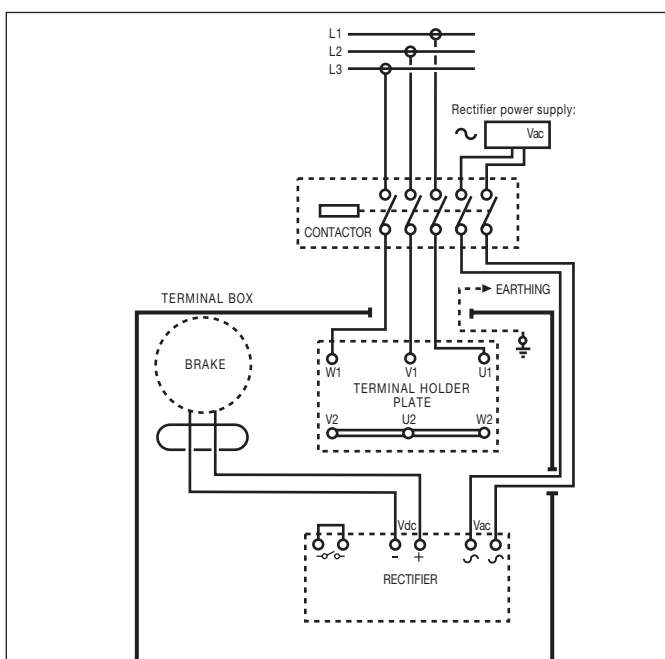

**Fig. 3 H** - Standard response time  
Independent brake power supply

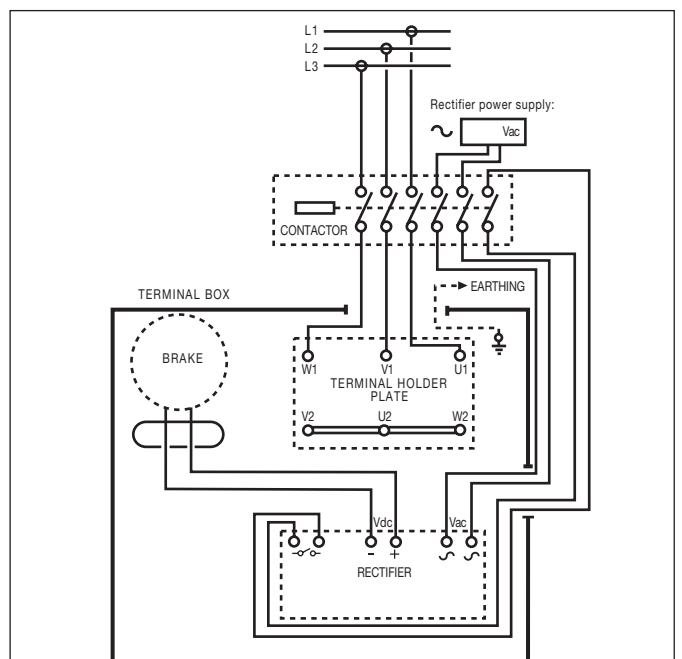

**Fig. 3 I** - Reduced response time  
Independent brake power supply

## 3.3

### 3.3.1 Brake power supply

### 3.3.2 Brake operating limits

### 3.3.3 Adjustments

#### 3.3.1 Brake power supply

---

In all cases, the brake works with uninterrupted voltage supplied by a rectifier installed on the terminal box of the motor supplied.

Two options are available for the alternative sinusoidal power supply of the rectifier:

##### **Power supply parallel with the motor power supply phases**

This is the simplest and most common way of using a brake.

In this configuration, it is not possible to set up two-speed motors or use a motor with a frequency converter.

Typical response times for the beginning of the lock are:

F63-71 : 32 ms ; F80 : 140 ms

Option: reduced response time.

Typical response times for the beginning of the lock are:

F63-71 : 10 ms ; F80 : 35 ms.

##### **Independent power supply**

The user must provide for an alternative sinusoidal power supply (230 or 400V  $\pm$  10%). This connection also allows using the motor with a frequency converter, but it requires an additional cable gland.

Option: reduced response time.

#### 3.3.2 Brake operating limits

---

The energy dissipated in the gasket over successive braking cycles should neither cause the brake to exceed the motor temperature class nor lead to early wear. Braking/hour, driving shaft inertia and motor speed should be indicated when a motor has to be chosen.

#### 3.3.3 Adjustments

---

Unless otherwise stated, motors are supplied with one of the braking torque values specified in Chapter 4.5 (Performance Data). However we have a procedure for adjusting or replacing the gasket if this is required during the use of the brake.

## 4. Performance data

- 4.1 Three-phase, 1-speed, ventilated motors
- 4.2 Three-phase, 1-speed, unventilated motors
- 4.3 Three-phase motors, 2 speeds, for general purpose (constant torque)
- 4.4 Three-phase motors, 2 speeds, for centrifugal machines (quadratic torque)
- 4.5 Three-phase, 1-speed, self-braking motors
- 4.6 Motors driven by inverter
- 4.7 Single-phase motors, 1 speed

## 4. *Données nominales*

- 4.1 *Moteurs triphasés, 1 vitesse, ventilés*
- 4.2 *Moteurs triphasés, 1 vitesse, non ventilés*
- 4.3 *Moteurs triphasés, 2 vitesses, pour usage général (couple constant)*
- 4.4 *Moteurs triphasés, 2 vitesses, pour machines centrifuges (couple quadratique)*
- 4.5 *Moteurs-freins triphasés, 1 vitesse*
- 4.6 *Moteurs avec alimentation par inverseur*
- 4.7 *Moteurs monophasés, 1 vitesse*

## 4. Betriebsdaten

- 4.1 Drehstrommotoren, 1 Drehzahl, belüftet
- 4.2 Drehstrommotoren, 1 Drehzahl, unbelüftet
- 4.3 Drehstrommotoren, 2 Drehzahlen, für allgemeinen Gebrauch (konstantes Gegenmoment)
- 4.4 Drehstrommotoren, 2 Drehzahlen, für Zentrifugalmaschinen (quadratisches Gegenmoment)
- 4.5 selbstbremsende Drehstrommotoren, 1 Drehzahl
- 4.6 Motoren für die Versorgung durch elektronische Frequenzumrichter
- 4.7 Einphasenmotoren, 1 Drehzahl

## 4. *Datos nominales*

- 4.1 *Motores trifásicos, 1 velocidad, ventilados*
- 4.2 *Motores trifásicos, 1 velocidad, no ventilados*
- 4.3 *Motores trifásicos, 2 velocidades, para uso general (par constante)*
- 4.4 *Motores trifásicos, 2 velocidades, para máquinas centrifugas (par cuadrático)*
- 4.5 *Motores con freno trifásicos, 1 velocidad*
- 4.6 *Motores con alimentación por medio de inverter*
- 4.7 *Motores monofásicos, 1 velocidad*

## 4. Dati nominali

- 4.1 Motori trifase, 1 velocità, ventilati
- 4.2 Motori trifase, 1 velocità, non ventilati
- 4.3 Motori trifase, 2 velocità, per uso generale (coppia costante)
- 4.4 Motori trifase, 2 velocità, per macchine centrifughe (coppia quadratica)
- 4.5 Motori autofrenanti trifase, 1 velocità
- 4.6 Motori con alimentazione a mezzo inverter
- 4.7 Motori monofase, 1 velocità

<b>GB</b>	Three-phase ventilated motors	<b>Speed</b>	<b>Rated data at</b>	<b>direct on line start</b>	<b>3000</b>	rpm	<b>GB</b>
<b>F</b>	Moteurs triphasés ventilés	<b>Vitesse</b>	<b>Données nominales à</b>	<b>démarrage direct</b>	<b>1500</b>	tours/min	<b>F</b>
<b>D</b>	Drehstrommotoren belüftet	<b>Drehzahl</b>	<b>Betriebsdaten bei</b>	<b>Direkteinschaltung</b>	<b>1000</b>	U/min	<b>D</b>
<b>E</b>	Motores trifásicos ventilados	<b>Velocidad</b>	<b>Datos nominales</b>	<b>arranque directo</b>	<b>750</b>	rev/min	<b>E</b>
<b>I</b>	Motori trifase ventilati	<b>Velocità</b>	<b>Dati nominali a</b>	<b>avviamento diretto</b>		giri/min	<b>I</b>

Motor type	Rated output	Speed	Current	Efficiency	Power factor	Torque	Starting current	Starting torque	Maximum torque	Sound pressure	Moment of inertia	Mass	LCIE Certificates	Class T
Moteur type	Puissance	Vitesse	Intensité	Rendement	Facteur de puissance	Couple	Intensité démarrage	Couple démarrage	Couple maximal	Pression sonore	Moment d'inertie	Masse	LCIE Certificat	Classe T
Motor Typ	Leistung	Drehzahl	Strom	Wirkungsgrad	Leistungsfaktor	Moment	Anlaufstrom	Anlaufmoment	Kippmoment	Gerauschwerte	Trägheitsmoment	Masse	LCIE Konformitäts-Bescheinigung	Klasse T
Tipo de motor	Potencia proporcionada	Velocidad	Corriente	Rendimiento	Factor de potencia	Par	Corriente de arranque	Par de arranque	Par máximo	Presión acústica	Momento de inercia	Peso	Certificados LCIE	Clase T
Tipo motore	Potenza resa	Velocità	Corrente	Rendimento	Fattore potenza	Coppia	Corrente avviamento	Coppia avviamento	Coppia massima	Pressione sonora	Momento d'inerzia	Massa	Certificato LCIE	Classe T

		P <sub>n</sub> [kW]	n [1/min]	I <sub>n</sub> * [A]	η [%]	cos φ	Mn [Nm]	Ia/In	Ma/Mn	Mm/Mn	Lp [dB(A)]	J ▼ [kgm <sup>2</sup> ]	m [kg]	IIB - IIC	
IIB Ex d Ex de	IIC Ex d Ex de													Ex d Ex de	
F 63 BTV A2	<b>F 63 CTV A2</b>	0.12	2850	0.40	54	0.89	0.40	5.3	2.6	2.8	62	0.0007	7.5	00 ATEX 6036	4
F 63 BTV A2	<b>F 63 CTV A2</b>	0.18	2780	0.56	53	0.88	0.61	4.0	2.2	2.4	62	0.0011	7.5	00 ATEX 6036	4
F 63 BTV A2	<b>F 63 CTV A2</b>	0.25	2840	0.70	63	0.89	0.84	5.7	3.0	3.3	62	0.0011	7.5	00 ATEX 6036	4
F 71 BTV B2	<b>F 71 CTV B2</b>	0.37	2820	0.95	65	0.90	1.24	5.0	2.3	2.4	64	0.0011	9.5	00 ATEX 6036	4
F 71 BTV C2	<b>F 71 CTV C2</b>	0.55	2790	1.35	67	0.90	1.88	4.7	2.1	2.3	64	0.0012	10.0	00 ATEX 6036	4
F 80 BTV A2 <sup>▲</sup>	<b>F 80 CTV A2<sup>▲</sup></b>	0.37	2945	0.95	74	0.79	1.20	10.0	5.0	5.4	66	0.0013	14.0	00 ATEX 6037	4
F 80 BTV A2 <sup>▲</sup>	<b>F 80 CTV A2<sup>▲</sup></b>	0.55	2920	1.20	80	0.85	1.80	8.0	4.0	4.3	66	0.0013	14.0	00 ATEX 6037	4
F 80 BTV A2	<b>F 80 CTV A2</b>	0.75	2925	1.80	79	0.77	2.40	7.0	4.0	4.4	66	0.0013	14.0	00 ATEX 6037	4
F 80 BTV B2	<b>F 80 CTV B2</b>	1.10	2885	2.30	81	0.86	3.60	6.0	2.8	3.0	66	0.0013	14.0	00 ATEX 6037	4
F 80 BTV C2 <sup>▲</sup>	<b>F 80 CTV C2<sup>▲</sup></b>	1.50	2905	3.40	80	0.82	4.90	7.9	3.6	3.8	66	0.0018	17.0	00 ATEX 6037	4
F 63 BTV A4	<b>F 63 CTV A4</b>	0.12	1435	0.55	54	0.58	0.80	4.5	4.7	4.9	55	0.0007	7.5	00 ATEX 6036	4
F 63 BTV A4	<b>F 63 CTV A4</b>	0.18	1405	0.65	60	0.73	1.20	3.9	3.0	3.2	55	0.0007	7.5	00 ATEX 6036	4
F 71 BTV B4	<b>F 71 CTV B4</b>	0.25	1425	0.75	65	0.77	1.60	4.6	2.8	3.0	56	0.0011	9.0	00 ATEX 6036	4
F 71 BTV B4	<b>F 71 CTV B4</b>	0.37	1430	1.15	66	0.70	2.40	4.8	2.6	2.8	56	0.0011	9.0	00 ATEX 6036	4
F 80 BTV A4 <sup>▲</sup>	<b>F 80 CTV A4<sup>▲</sup></b>	0.37	1450	1.30	64	0.67	2.40	6.3	4.4	4.6	56	0.0023	12.0	00 ATEX 6037	4
F 80 BTV A4	<b>F 80 CTV A4</b>	0.55	1445	1.45	78	0.70	3.60	5.7	3.3	3.6	56	0.0023	12.0	00 ATEX 6037	4
F 80 BTV B4	<b>F 80 CTV B4</b>	0.75	1415	1.85	80	0.82	5.00	4.7	2.2	2.4	56	0.0023	12.0	00 ATEX 6037	4
F 80 BTV C4 <sup>▲</sup>	<b>F 80 CTV C4<sup>▲</sup></b>	1.10	1430	2.70	77	0.76	7.30	4.9	2.6	2.8	56	0.0029	14.0	00 ATEX 6037	4
F 63 BTV A6	<b>F 63 CTV A6</b>	0.12	930	0.55	50	0.61	1.20	2.7	1.6	1.7	52	0.0011	7.5	00 ATEX 6036	4
F 71 BTV B6	<b>F 71 CTV B6</b>	0.18	925	0.90	49	0.60	1.90	2.3	1.5	1.6	52	0.0012	9.5	00 ATEX 6036	4
F 71 BTV B6	<b>F 71 CTV B6</b>	0.25	890	0.90	53	0.77	2.70	2.5	1.4	1.5	52	0.0014	10.0	00 ATEX 6036	4
F 80 BTV A6 <sup>▲</sup>	<b>F 80 CTV A6<sup>▲</sup></b>	0.25	950	0.90	60	0.62	2.50	4.0	2.4	2.6	54	0.0023	12.0	00 ATEX 6037	4
F 80 BTV A6	<b>F 80 CTV A6</b>	0.37	930	1.10	65	0.74	3.80	3.0	1.6	1.8	54	0.0023	12.0	00 ATEX 6037	4
F 80 BTV B6	<b>F 80 CTV B6</b>	0.55	920	1.75	68	0.70	5.60	3.8	2.2	2.4	54	0.0029	14.0	00 ATEX 6037	4
F 80 BTV C6 <sup>▲</sup>	<b>F 80 CTV C6<sup>▲</sup></b>	0.75	880	2.15	64	0.78	8.10	2.9	1.5	1.7	54	0.0029	14.0	00 ATEX 6037	4
F 63 BTV B8	<b>F 63 CTV B8</b>	0.075	660	0.35	47	0.57	1.10	2.0	1.3	1.3	44	0.0008	9.0	00 ATEX 6036	4
F 71 BTV C8	<b>F 71 CTV C8</b>	0.12	675	0.60	45	0.63	1.70	2.5	2.2	2.3	46	0.0014	10.0	00 ATEX 6036	4
F 71 BTV C8 <sup>▲</sup>	<b>F 71 CTV C8<sup>▲</sup></b>	0.18	660	1.05	50	0.50	2.60	2.2	1.8	1.9	46	0.0014	10.0	00 ATEX 6036	4
F 80 BTV A8	<b>F 80 CTV A8</b>	0.18	705	0.95	54	0.50	2.40	3.0	2.4	2.5	48	0.0023	12.0	00 ATEX 6037	4
F 80 BTV B8	<b>F 80 CTV B8</b>	0.25	690	1.05	57	0.60	3.40	2.6	1.7	1.8	48	0.0023	12.0	00 ATEX 6037	4
F 80 BTV C8 <sup>▲</sup>	<b>F 80 CTV C8<sup>▲</sup></b>	0.37	705	1.40	64	0.59	5.00	3.0	2.2	2.3	48	0.0029	14.0	00 ATEX 6037	4

▲ non-standard power  
puissance non normalisée  
nicht genormte Leistung  
potencia no normalizada  
potenza non normalizzata

\* I<sub>n</sub> = I<sub>n</sub> ·  $\frac{400}{U}$  (I<sub>n</sub> = current at U' Volt);  
(I<sub>n</sub> = intensité à U' Volt);  
(I<sub>n</sub> = Strom mit U' Volt);  
(I<sub>n</sub> = corriente de U' Voltios);  
(I<sub>n</sub> = corrente a U' Volt);

▼ J =  $\frac{PD^2}{4}$

<b>GB</b>	Three-phase unventilated motors	<b>Speed</b>	<b>Rated data at</b>	<b>direct on line start</b>	<b>3000</b>	<b>rpm</b>	<b>GB</b>
<b>F</b>	Moteurs triphasés non ventilés	<b>Vitesse</b>	<b>Données nominales à</b>	<b>démarrage direct</b>	<b>1500</b>	<b>tours/min</b>	<b>F</b>
<b>D</b>	Drehstrommotoren unbelüftet	<b>Drehzahl</b>	<b>Betriebsdaten bei</b>	<b>Direkteinschaltung</b>	<b>1000</b>	<b>U/min</b>	<b>D</b>
<b>E</b>	Motores trifásicos no ventilados	<b>Velocidad</b>	<b>Datos nominales</b>	<b>arranque directo</b>	<b>750</b>	<b>rev/min</b>	<b>E</b>
<b>I</b>	Motori trifase non ventilati	<b>Velocità</b>	<b>Dati nominali a</b>	<b>avviamento diretto</b>		<b>giri/min</b>	<b>I</b>

**400 V**  
**50 Hz**

Motor type	Rated output	Speed	Current	Efficiency	Power factor	Torque	Starting current	Starting torque	Maximum torque	Sound pressure	Moment of inertia	Mass	LCIE Certificates	Class T
<i>Motor type</i>	<i>Puissance</i>	<i>Vitesse</i>	<i>Intensité</i>	<i>Rendement</i>	<i>Facteur de puissance</i>	<i>Couple</i>	<i>Intensité démarrage</i>	<i>Couple démarrage</i>	<i>Couple maximal</i>	<i>Pression sonore</i>	<i>Moment d'inertie</i>	<i>Masse</i>	<i>LCIE Certificat</i>	<i>Classe T</i>
Motor Typ	Leistung	Drehzahl	Strom	Wirkungsgrad	Leistungsfaktor	Moment	Anlaufstrom	Anlaufmoment	Kippmoment	Gerauschwerte	Trägheitsmoment	Masse	LCIE Konformitäts-Bescheinigung	Klasse T
<i>Tipo de motor</i>	<i>Potencia proporcionada</i>	<i>Velocidad</i>	<i>Corriente</i>	<i>Rendimiento</i>	<i>Factor de potencia</i>	<i>Par</i>	<i>Corriente de arranque</i>	<i>Par de arranque</i>	<i>Par máximo</i>	<i>Presión acústica</i>	<i>Momento de inercia</i>	<i>Peso</i>	<i>Certificados LCIE</i>	<i>Clase T</i>
Tipo motore	Potenza resa	Velocità	Corrente	Rendimento	Fattore potenza	Coppia	Corrente avviamento	Coppia avviamento	Coppia massima	Pressione sonora	Momento d'inerzia	Massa	Certificato LCIE	Classe T
IIB	IIC	P <sub>n</sub>	n	I <sub>n</sub> *	η	cos φ	Mn	Ia/In	Ma/Mn	Mm/Mn	Lp	J ▼	m	IIB - IIC
Ex d	Ex d	[kW]	[1/min]	[A]	[%]		[Nm]				[dB(A)]	[kgm <sup>2</sup> ]	[kg]	Ex d
F 56 BST A2*	<b>F 56 CST A2*</b>	0.06	2825	0.27	53	0.69	0.20	4.0	5.0	5.2	51	0.00012	4.5	00 ATEX 6035
F 56 BST A2*	<b>F 56 CST A2*</b>	0.09	2760	0.31	60	0.76	0.30	3.5	4.0	4.2	51	0.00012	4.5	00 ATEX 6035
F 63 BST A2		0.12	2850	0.40	54	0.89	0.40	5.3	2.6	2.8	55	0.00060	6.5	00 ATEX 6036
F 63 BST A2		0.18	2780	0.56	53	0.88	0.60	4.0	2.2	2.4	55	0.00060	6.5	00 ATEX 6036
F 63 BST B2		0.25	2840	0.70	63	0.89	0.84	5.7	3.0	3.2	55	0.00070	7.5	00 ATEX 6036
F 71 BST C2		0.37	2880	0.95	71	0.80	1.20	6.0	4.0	4.2	58	0.00070	8.0	00 ATEX 6036
F 80 BST A2^	<b>F 80 CST A2^</b>	0.37	2945	0.95	71	0.79	1.20	8.0	4.0	4.2	60	0.0012	12.0	00 ATEX 6037
F 80 BST A2^	<b>F 80 CST A2^</b>	0.55	2920	1.20	78	0.85	1.80	8.0	4.0	4.2	60	0.0012	12.0	00 ATEX 6037
F 56 BST A4*	<b>F 56 CST A4*</b>	0.06	1420	0.37	50	0.50	0.40	3.5	4.0	4.2	51	0.0002	4.5	00 ATEX 6035
F 56 BST A4*	<b>F 56 CST A4*</b>	0.09	1370	0.40	57	0.62	0.60	3.0	3.5	3.7	51	0.0002	4.5	00 ATEX 6035
F 63 BST A4		0.12	1450	0.50	60	0.64	0.80	5.7	5.4	5.6	55	0.0006	6.5	00 ATEX 6036
F 63 BST A4		0.18	1430	0.58	65	0.73	1.20	5.0	3.5	3.7	55	0.0006	6.5	00 ATEX 6036
F 71 BST B4		0.25	1425	0.75	65	0.77	1.60	5.0	2.8	2.9	55	0.0007	7.5	00 ATEX 6036
F 71 BST C4		0.37*	1390	1.00	68	0.78	2.50	4.5	2.3	2.5	58	0.0008	8.0	00 ATEX 6036
F 80 BST A4^	<b>F 80 CST A4^</b>	0.37	1450	1.30	61	0.67	2.40	6.6	4.0	4.2	60	0.0021	11.0	00 ATEX 6037
F 80 BST B4	<b>F 80 CST B4</b>	0.55	1445	1.50	74	0.72	3.60	5.5	2.8	3.0	60	0.0021	11.0	00 ATEX 6037
F 80 BST C4	<b>F 80 CST C4</b>	0.75	1410	1.90	75	0.78	5.00	5.0	3.4	3.5	60	0.0027	14.0	00 ATEX 6037
F 56 BST A6*	<b>F 56 CST A6*</b>	0.06	890	0.35	43	0.72	0.60	2.6	2.9	2.9	51	---	---	00 ATEX 6035
F 63 BST B6		0.12	930	0.55	55	0.63	1.20	2.7	1.6	1.7	55	0.0007	7.5	00 ATEX 6036
F 71 BST B6		0.18	925	0.90	48	0.60	1.80	2.7	2.5	2.6	55	0.0009	8.0	00 ATEX 6036
F 80 BST A6^	<b>F 80 CST A6^</b>	0.25	950	0.90	65	0.62	2.50	3.6	2.4	2.6	60	0.0021	11.0	00 ATEX 6037
F 80 BST B6	<b>F 80 CST B6</b>	0.37	930	1.10	65	0.74	3.80	3.0	1.6	1.7	60	0.0021	11.0	00 ATEX 6037
F 80 BST C6	<b>F 80 CST C6</b>	0.55	920	1.75	66	0.70	5.60	3.3	2.2	2.4	60	0.0027	12.0	00 ATEX 6037
F 63 BST B8		0.075	650	0.40	45	0.60	1.10	2.0	1.3	1.4	51	0.0007	6.5	00 ATEX 6036
F 71 BST C8		0.12	675	0.60	46	0.63	1.70	2.0	1.6	1.7	55	0.0011	7.5	00 ATEX 6036
F 80 BST B8	<b>F 80 CST B8</b>	0.18	705	0.95	55	0.50	2.40	3.0	2.5	2.7	60	0.0021	11.0	00 ATEX 6037
F 80 BST B8	<b>F 80 CST B8</b>	0.25	690	1.05	57	0.60	3.50	2.6	1.7	1.9	60	0.0021	11.0	00 ATEX 6037
F 80 BST C8^	<b>F 80 CST C8^</b>	0.37	705	1.40	66	0.59	5.00	3.0	1.8	1.9	60	0.0027	12.0	00 ATEX 6037

▲ non-standard power  
puissance non normalisée  
nicht genormte Leistung  
potencia no normalizada  
potenza non normalizzata

◆ S1 service only in ambient air flow at 40° C  
Service S1 uniquement dans un flux d'air ambiant à 40°C  
Service S1 nur bei Raumluftstrom von 40° C  
Servicio S1 únicamente en flujo de aire ambiente a 40° C  
Servizio S1 unicamente in flusso d'aria ambiente a 40° C

● Short  
Court  
Kurz  
Corto  
Corto

■ Long  
Long  
Lang  
Largo  
Lungo

\* I<sub>n</sub> = I<sub>n</sub> ·  $\frac{400}{U}$   
(I<sub>n</sub> = current at U' Volt);  
(I<sub>n</sub> = intensité à U' Volt);  
(I<sub>n</sub> = Strom mit U' Volt);  
(I<sub>n</sub> = corriente de U' Voltios);  
(I<sub>n</sub> = corrente a U' Volt);

▼ J =  $\frac{PD^2}{4}$

GB	F	D	E	I	4.	4.3	Three-phase motors		Speed		Rated data at		direct on line start		for general purpose (constant torque)					rpm	GB		
							Moteurs triphasés	Motors trifásicos	Vitesse	Velocidad	Données nominales à	Datos nominales	démarrage direct	arranque directo	pour usage général (couple constant)	für allgemeinen Gebrauch (konstantes Gegenmoment)	para uso general (par constante)	per uso generale (coppia costante)	tours/min			F	
							Drehstrom Motoren		Drehzahl		Betriebsdaten bei		Direkteinschaltung		für allgemeinen Gebrauch (konstantes Gegenmoment)					U/min		D	
							Motores trifásicos		Velocidad		Datos nominales		arranque directo		para uso general (par constante)					rev/min		E	
							Motori trifase		Velocità		Dati nominali a		avviamento diretto		per uso generale (coppia costante)					giri/min		I	
							Motor type		Rated output	Speed	Current	Efficiency	Power factor	Torque	Starting current	Starting torque	Maximum torque	Sound pressure	Moment of inertia	Mass	LCIE Certificates		Class T
							Moteur type		Puissance	Vitesse	Intensité	Rendement	Facteur de puissance	Couple	Intensité démarrage	Couple démarrage	Couple maximal	Pression sonore	Moment d'inertie	Masse	LCIE Certificat		Classe T
							Motor Typ		Leistung	Drehzahl	Strom	Wirkungsgrad	Leistungsfaktor	Moment	Anlaufstrom	Anlaufmoment	Kippmoment	Gerauschwerte	Trägheitsmoment	Masse	LCIE Konformitäts-Bescheinigung		Klasse T
							Tipo de motor		Potencia proporcionada	Velocidad	Corriente	Rendimiento	Factor de potencia	Par	Corriente de arranque	Par de arranque	Par máximo	Presión acústica	Momento de inercia	Peso	Certificados LCIE		Clase T
							Tipo motore		Potenza resa	Velocità	Corrente	Rendimento	Fattore potenza	Coppia	Corrente avviamento	Coppia avviamento	Coppia massima	Pressione sonora	Momento d'inerzia	Massa	Certificato LCIE		Classe T
IIB		IIC		P <sub>n</sub> [kW]	n [1/min]	I <sub>n</sub> * [A]	η [%]	cos φ	Mn [Nm]	Ia/In	Ma/Mn	Mm/Mn	Lp [dB(A)]	J ▼ [kgm <sup>2</sup> ]	m [kg]	IIB - IIC							
Ex d Ex de	Ex d Ex de	Ex d Ex de																					
F 63 BTV C2-4	F 63 CTV C2-4	0.25 0.18	2720 1440	0.80 1.05	56 47	0.90 0.58	0.88 1.19	3.3 3.4	2.5 3.0	2.7 3.2	64 56	0.0011	9.5	00 ATEX 6036		4							
F 80 BTV B2-4	F 80 CTV B2-4	0.55 0.37	2905 1465	1.80 1.25	64 66	0.70 0.65	1.81 2.41	5.0 5.6	2.9 3.5	3.1 3.7	66 56	0.0023	12.0	00 ATEX 6037		4							
F 80 BTV C2-4	F 80 CTV C2-4	0.75 0.55	2815 1440	2.80 1.80	58 64	0.70 0.72	2.55 3.65	3.7 5.2	3.9 3.6	4.1 3.8	66 56	0.0029	14.0	00 ATEX 6037		4							
F 71 BTV C4-6	F 71 CTV C4-6	0.18 0.12	1440 685	0.65 0.80	55 39	0.76 0.57	1.19 1.67	4.5 2.1	3.0 2.2	3.3 2.3	56 52	0.0011	9.5	00 ATEX 6036		4							
F 80 BTV B4-6	F 80 CTV B4-6	0.37 0.25	1460 940	1.20 0.95	76 54	0.72 0.78	2.42 2.54	5.0 2.3	2.7 1.0	2.8 1.2	56 54	0.0023	12.0	00 ATEX 6037		4							
F 80 BTV B4-6	F 80 CTV B4-6	0.55 0.30	1450 950	1.70 1.00	73 60	0.71 0.70	3.62 3.02	5.0 3.0	2.6 2.1	2.7 2.2	56 54	0.0029	14.0	00 ATEX 6037		4							
F 80 BTV C4-6	F 80 CTV C4-6	0.75 0.37	1410 940	2.00 1.15	71 65	0.85 0.73	5.08 3.76	4.5 3.1	2.0 1.3	2.2 1.4	56 54	0.0029	14.0	00 ATEX 6037		4							
F 71 BTV C4-8	F 71 CTV C4-8	0.18 0.12	1430 675	0.65 0.80	53 37	0.78 0.63	1.20 1.70	4.0 2.0	2.3 2.1	2.5 2.2	56 46	0.0011	9.5	00 ATEX 6036		4							
F 80 BTV B4-8	F 80 CTV B4-8	0.55 0.25	1405 710	1.45 1.45	62 46	0.87 0.54	3.74 3.36	5.0 2.2	2.0 1.8	2.1 1.9	56 48	0.0023	12.0	00 ATEX 6037		4							
F 80 BTV C4-8	F 80 CTV C4-8	0.75 0.37	1380 710	1.80 2.10	71 55	0.87 0.50	5.19 4.98	4.4 2.8	2.2 2.5	2.4 2.7	56 48	0.0029	14.0	00 ATEX 6037		4							

Frame size 56: contact us for further information

Hauteur d'axe 56 : nous consulter

Achsenhöhe 56: Kontaktieren Sie uns.

Altura de eje 56 estamos a su disposición

Altezza d'asse 56: su richiesta

$$* I'_n = I_n \cdot \frac{400}{U}$$

(I<sub>n</sub> = current at U' Volt);  
(I<sub>n</sub> = intensité à U' Volt);  
(I<sub>n</sub> = Strom mit U' Volt);  
(I<sub>n</sub> = corriente de U' Voltios);  
(I<sub>n</sub> = corrente a U' Volt);

$$\nabla J = \frac{PD^2}{4}$$



<b>GB</b>	Three-phase motors	<b>Speed</b>	<b>Rated data at</b>	<b>direct on line start</b>	<b>for centrifugal machines (quadratic torque)</b>	<b>3000/1500</b>	<b>rpm</b>	<b>GB</b>
<b>F</b>	Moteurs triphasés	<b>Vitesse</b>	<b>Données nominales à</b>	<b>démarrage direct</b>	<b>pour machines centrifuges (couple quadratique)</b>	<b>1500/750</b>	<b>tours/min</b>	<b>F</b>
<b>D</b>	Drehstrom Motoren	<b>Drehzahl</b>	<b>Betriebsdaten bei</b>	<b>Direkteinschaltung</b>	<b>für Zentrifugalmaschinen (quadratisches Gegenmoment)</b>	<b>1500/1000</b>	<b>U/min</b>	<b>D</b>
<b>E</b>	Motores trifásicos	<b>Velocidad</b>	<b>Datos nominales</b>	<b>arranque directo</b>	<b>para máquinas centrifugas (par cuadrático)</b>	<b>1000/500</b>	<b>rev/min</b>	<b>E</b>
<b>I</b>	Motori trifase	<b>Velocità</b>	<b>Dati nominali a</b>	<b>avviamento diretto</b>	<b>per macchine centrifughe (coppia quadratica)</b>		<b>giri/min</b>	<b>I</b>

Motor type	Rated output	Speed	Current	Efficiency	Power factor	Torque	Starting current	Starting torque	Maximum torque	Sound pressure	Moment of inertia	Mass	LCIE Certificates	Class T
Moteur type	Puissance	Vitesse	Intensité	Rendement	Facteur de puissance	Couple	Intensité démarrage	Couple démarrage	Couple maximal	Pression sonore	Moment d'inertie	Masse	LCIE Certificat	Classe T
Motor Typ	Leistung	Drehzahl	Strom	Wirkungsgrad	Leistungsfaktor	Moment	Anlaufstrom	Anlaufmoment	Kippmoment	Gerauschwerte	Trägheitsmoment	Masse	LCIE Konformitäts-Bescheinigung	Klasse T
Tipo de motor	Potencia proporcionada	Velocidad	Corriente	Rendimiento	Factor de potencia	Par	Corriente de arranque	Par de arranque	Par máximo	Presión acústica	Momento de inercia	Peso	Certificados LCIE	Clase T
Tipo motore	Potenza resa	Velocità	Corrente	Rendimento	Fattore potenza	Coppia	Corrente avviamento	Coppia avviamento	Coppia massima	Pressione sonora	Momento d'inerzia	Massa	Certificato LCIE	Classe T

		$P_n$	$n$	$I_n^*$	$\eta$	$\cos \varphi$	$M_n$	$I_a/I_n$	$M_a/M_n$	$M_m/M_n$	$L_p$	$J \nabla$	$m$	IIB - IIC	
IIB	IIC	[kW]	[1/min]	[A]	[%]		[Nm]				[dB(A)]	[kgm <sup>2</sup> ]	[kg]	Ex d Ex de	
Ex d Ex de	Ex d Ex de														
F 63 BTV B2-4	<b>F 63 CTV B2-4</b>	0.25 0.06	2810 1435	0.90 0.40	56 38	0.76 0.66	0.85 0.45	4.60 3.70	4.60 2.40	4.80 2.50	62 55	0.0011	9.0	00 ATEX 6036	4
F 71 BTV C2-4	<b>F 71 CTV C2-4</b>	0.37 0.09	2835 1440	1.05 0.50	62 39	0.85 0.69	1.25 0.60	5.70 3.70	3.60 2.00	3.80 2.20	64 56	0.0012	9.5	00 ATEX 6036	4
F 80 BTV B2-4	<b>F 80 CTV B2-4</b>	0.55 0.13	2905 1445	1.80 0.45	66 57	0.70 0.76	1.80 0.85	4.40 5.00	2.00 3.00	2.30 3.10	66 56	0.0023	12.0	00 ATEX 6037	4
F 80 BTV B2-4	<b>F 80 CTV B2-4</b>	0.75 0.18	2840 1420	2.10 0.55	67 62	0.78 0.83	2.50 1.20	4.60 4.60	2.20 2.20	2.40 2.30	66 56	0.0023	12.0	00 ATEX 6037	4
F 80 BTV C2-4	<b>F 80 CTV C2-4</b>	1.10 0.28	2760 1420	4.10 0.75	63 67	0.65 0.81	3.80 1.90	4.00 4.00	2.00 2.10	2.30 2.20	66 56	0.0029	14.0	00 ATEX 6037	4
F 63 BTV B4-8	<b>F 63 CTV B4-8</b>	0.18 0.03	1440 695	0.70 0.30	51 32	0.75 0.78	1.20 0.40	4.77 2.30	3.60 2.40	3.80 2.50	55 44	0.0011	9.0	00 ATEX 6036	4
F 71 BTV C4-8	<b>F 71 CTV C4-8</b>	0.25 0.06	1430 670	1.05 0.45	56 34	0.63 0.57	1.70 0.85	3.90 2.60	2.80 2.00	3.00 2.20	56 46	0.0012	9.5	00 ATEX 6036	4
F 80 BTV C4-8	<b>F 80 CTV C4-8</b>	0.37 0.09	1430 675	1.30 0.50	69 45	0.70 0.59	2.50 1.27	6.00 2.80	3.00 2.40	3.20 2.50	56 48	0.0023	12.0	00 ATEX 6037	4
F 80 BTV B4-8	<b>F 80 CTV B4-8</b>	0.55 0.13	1440 700	1.40 0.65	71 50	0.79 0.60	3.60 1.77	5.20 2.60	2.20 1.90	2.40 2.00	56 48	0.0023	12.0	00 ATEX 6037	4
F 80 BTV B4-8	<b>F 80 CTV B4-8</b>	0.75 0.18	1430 670	2.10 1.20	73 50	0.77 0.62	5.00 2.50	4.80 2.50	2.00 2.40	2.20 2.50	56 48	0.0029	14.0	00 ATEX 6037	4
F 80 BTV C4-8	<b>F 80 CTV C4-8</b>	1.10 0.28	1425 690	3.10 1.20	71 52	0.72 0.64	7.30 3.80	5.00 4.60	2.40 2.20	2.60 2.30	56 48	0.0029	14.0	00 ATEX 6037	4
F 63 BTV B4-6	<b>F 63 CTV B4-6</b>	0.18 0.06	1450 970	0.70 0.55	54 30	0.84 0.55	1.19 0.59	3.50 2.50	1.60 2.80	1.80 2.90	55 52	0.0011	9.5	00 ATEX 6036	4
F 71 BTV C4-6	<b>F 71 CTV C4-6</b>	0.25 0.08	1420 955	0.85 0.55	58 38	0.81 0.62	1.68 0.80	3.00 2.40	1.20 2.50	1.40 2.60	56 52	0.0011	9.5	00 ATEX 6036	4
F 80 BTV A4-6	<b>F 80 CTV A4-6</b>	0.37 0.12	1460 975	1.20 0.75	64 41	0.72 0.59	2.42 1.18	5.20 3.00	1.60 3.00	1.80 3.20	56 54	0.0023	14.0	00 ATEX 6037	4
F 80 BTV B4-6	<b>F 80 CTV B4-6</b>	0.55 0.18	1450 965	1.70 0.90	73 58	0.71 0.63	3.62 1.78	5.50 3.60	2.50 2.30	2.70 2.50	56 54	0.0029	16.0	00 ATEX 6037	4
F 80 BTV C4-6	<b>F 80 CTV C4-6</b>	0.75 0.25	1450 960	2.00 0.95	73 64	0.74 0.60	4.94 2.49	5.00 3.40	2.40 2.20	2.50 2.20	56 54	0.0029	16.0	00 ATEX 6037	4
F 71 BTV C6-12	<b>F 71 CTV C6-12</b>	0.12 0.03	950 430	0.80 0.35	44 24	0.49 0.53	1.21 0.67	3.00 1.50	3.50 2.20	3.60 2.25	55 52	0.0011	9.5	00 ATEX 6036	4
F 80 BTV B6-12	<b>F 80 CTV B6-12</b>	0.37 0.06	960 470	1.60 0.65	59 30	0.58 0.45	3.68 1.22	3.20 2.70	2.20 1.70	2.30 1.80	56 54	0.0023	14.0	00 ATEX 6037	4
F 80 BTV C6-12	<b>F 80 CTV C6-12</b>	0.65 0.10	900 450	1.95 1.00	63 30	0.80 0.55	6.90 2.12	2.80 1.40	1.50 1.40	1.60 1.50	56 54	0.0029	16.0	00 ATEX 6037	4

Frame size 56: contact us for further information  
 Hauteur d'axe 56: nous consulter  
 Achsenhöhe 56: Kontaktieren Sie uns.  
 Altura de eje 56 estamos a su disposición  
 Altezza d'asse 56: su richiesta

$$* I'_n = I_n \cdot \frac{400}{U'}$$

( $I'_n$  = current at U' Volt);  
 ( $I'_n$  = intensité à U' Volt);  
 ( $I'_n$  = Strom mit U' Volt);  
 ( $I'_n$  = corriente de U' Voltios);  
 ( $I'_n$  = corrente a U' Volt);

$$\nabla J = \frac{PD^2}{4}$$

<b>GB</b>	Self-braking motors	<b>Speed</b>	<b>Rated data at</b>	<b>direct on line start</b>	<b>3000</b>	<b>rpm</b>	<b>GB</b>
<b>F</b>	Moteurs freins	<b>Vitesse</b>	<b>Données nominales à</b>	<b>démarrage direct</b>	<b>1500</b>	<b>tours/min</b>	<b>F</b>
<b>D</b>	Selbstbremsende Motoren	<b>Drehzahl</b>	<b>Betriebsdaten bei</b>	<b>Direkteinschaltung</b>	<b>1000</b>	<b>U/min</b>	<b>D</b>
<b>E</b>	Motores con freno	<b>Velocidad</b>	<b>Datos nominales</b>	<b>arranque directo</b>	<b>750</b>	<b>rev/min</b>	<b>E</b>
<b>I</b>	Motori autofrenanti	<b>Velocità</b>	<b>Dati nominali a</b>	<b>avviamento diretto</b>		<b>giri/min</b>	<b>I</b>

Motor type	Rated output	Speed	Current	Efficiency	Power factor	Torque	Starting current	Starting torque	Maximum torque	Sound pressure	Moment of inertia	Mass	Braking torque	LCIE Certificates	Class T
Moteur type	Puissance	Vitesse	Intensité	Rendement	Facteur de puissance	Couple	Intensité démarrage	Couple démarrage	Couple maximal	Pression sonore	Moment d'inertie	Masse	Couple de freinage	LCIE Certificat	Classe T
Motor Typ	Leistung	Drehzahl	Strom	Wirkungsgrad	Leistungsfaktor	Moment	Anlaufstrom	Anlaufmoment	Kippmoment	Gerauschwerte	Trägheitsmoment	Masse	Bremsmoment	LCIE Konformitäts-Bescheinigung	Klasse T
Tipo de motor	Potencia proporcionada	Velocidad	Corriente	Rendimiento	Factor de potencia	Par	Corriente de arranque	Par de arranque	Par máximo	Presión acústica	Momento de inercia	Peso	Par de frenado	Certificados LCIE	Clase T
Tipo motore	Potenza resa	Velocità	Corrente	Rendimento	Fattore potenza	Coppia	Corrente avviamento	Coppia avviamento	Coppia massima	Pressione sonora	Momento d'inerzia	Massa	Coppia frenante	Certificato LCIE	Classe T

		$P_n$	$n$	$I_n^*$	$\eta$	$\cos \varphi$	$M_n$	$I_a/I_n$	$M_a/M_n$	$M_m/M_n$	$L_p$	$J \nabla$	$m$	$N_m$	IIB - IIC	
IIB	IIC	[kW]	[1/min]	[A]	[%]		[Nm]				[dB(A)]	[kgm <sup>2</sup> ]	[kg]		Ex d	
Ex d	Ex de														Ex de	
F 63 BTVF A2	<b>F 63 CTVF A2</b>	0.12	2850	0.40	54	0.89	0.40	5.3	2.6	2.8	62	0.0008	9.5	4	00 ATEX 6036	4
F 63 BTVF A2	<b>F 63 CTVF A2</b>	0.18	2780	0.56	53	0.88	0.61	4.0	2.2	2.4	62	0.0008	9.5	4	00 ATEX 6036	4
F 63 BTVF A2	<b>F 63 CTVF A2</b>	0.25	2840	0.70	63	0.89	0.84	5.7	3.0	3.3	62	0.0008	9.5	4	00 ATEX 6036	4
F 71 BTVF B2	<b>F 71 CTVF B2</b>	0.37	2820	0.95	65	0.90	1.24	5.0	2.3	2.4	64	0.0012	11.5	4	00 ATEX 6036	4
F 80 BTVF A2	<b>F 80 CTVF A2</b>	0.37	2945	0.95	74	0.79	1.20	10.0	5.0	5.4	66	0.0015	12.0	16	00 ATEX 6037	4
F 80 BTVF A2	<b>F 80 CTVF A2</b>	0.55	2920	1.20	80	0.85	1.80	8.0	4.0	4.3	66	0.0015	18.5	16	00 ATEX 6037	4
F 80 BTVF A2	<b>F 80 CTVF A2</b>	0.75	2925	1.80	79	0.77	2.40	7.0	4.0	4.4	66	0.0017	18.5	16	00 ATEX 6037	4
F 80 BTVF B2	<b>F 80 CTVF B2</b>	1.10	2885	2.30	81	0.86	3.60	6.0	2.8	3.0	66	0.0017	18.5	16	00 ATEX 6037	4
F 63 BTVF A4	<b>F 63 CTVF A4</b>	0.12	1435	0.55	54	0.58	0.80	4.5	4.7	4.9	55	0.0008	9.5	4	00 ATEX 6036	4
F 63 BTVF A4	<b>F 63 CTVF A4</b>	0.18	1405	0.65	60	0.73	1.20	3.9	3.0	3.2	55	0.0008	9.5	4	00 ATEX 6036	4
F 71 BTVF B4	<b>F 71 CTVF B4</b>	0.25	1425	0.75	65	0.77	1.60	4.6	2.8	3.0	56	0.0012	11.0	4	00 ATEX 6036	4
F 71 BTVF B4	<b>F 71 CTVF B4</b>	0.37	1430	1.15	66	0.70	2.40	4.8	2.6	2.8	56	0.0012	11.0	4	00 ATEX 6036	4
F 80 BTVF A4	<b>F 80 CTVF A4</b>	0.37	1450	1.30	64	0.67	2.40	6.3	4.4	4.6	56	0.0025	16.0	16	00 ATEX 6037	4
F 80 BTVF A4	<b>F 80 CTVF A4</b>	0.55	1445	1.45	78	0.70	3.60	5.7	3.3	3.6	56	0.0025	16.0	16	00 ATEX 6037	4
F 80 BTVF B4	<b>F 80 CTVF B4</b>	0.75	1415	1.85	80	0.82	5.00	4.7	2.2	2.4	56	0.0025	16.0	16	00 ATEX 6037	4
F 63 BTVF B6	<b>F 63 CTVF B6</b>	0.12	930	0.55	50	0.61	1.20	2.7	1.6	1.7	52	0.0012	11.0	4	00 ATEX 6036	4
F 71 BTVF C6	<b>F 71 CTVF C6</b>	0.18	925	0.90	49	0.60	1.90	2.3	1.5	1.6	52	0.0013	11.5	4	00 ATEX 6036	4
F 71 BTVF C6	<b>F 71 CTVF C6</b>	0.25	890	0.90	53	0.77	2.70	2.5	1.4	1.5	52	0.0013	11.5	4	00 ATEX 6036	4
F 80 BTVF A6	<b>F 80 CTVF A6</b>	0.25	950	0.90	60	0.62	2.50	4.0	2.4	2.6	54	0.0025	16.0	16	00 ATEX 6037	4
F 80 BTVF A6	<b>F 80 CTVF A6</b>	0.37	930	1.10	65	0.74	3.80	3.0	1.6	1.8	54	0.0025	16.0	16	00 ATEX 6037	4
F 80 BTVF C6	<b>F 80 CTVF C6</b>	0.55	920	1.75	68	0.70	5.60	3.8	2.2	2.4	54	0.0025	18.0	16	00 ATEX 6037	4
F 63 BTVF B8	<b>F 63 CTVF B8</b>	0.075	660	0.35	47	0.57	1.10	2.0	1.3	1.3	44	0.0012	9.0	4	00 ATEX 6036	4
F 71 BTVF C8	<b>F 71 CTVF C8</b>	0.12	675	0.60	45	0.63	1.70	2.5	2.2	2.3	46	0.0013	10.0	4	00 ATEX 6036	4
F 71 BTVF C8	<b>F 71 CTVF C8</b>	0.18	660	1.05	50	0.50	2.60	2.2	1.8	1.9	46	0.0013	10.0	4	00 ATEX 6036	4
F 80 BTVF B8	<b>F 80 CTVF B8</b>	0.25	690	1.05	57	0.60	3.40	2.6	1.7	1.8	48	0.0025	16.0	16	00 ATEX 6037	4
F 80 BTVF C8	<b>F 80 CTVF C8</b>	0.37	705	1.40	64	0.59	5.00	3.0	2.2	2.3	48	0.0030	18.0	16	00 ATEX 6037	4

◆ Contact us for further information

Nous consulter

Kontaktieren Sie uns.

Estamos a su disposición

Su richiesta

$$* I'_n = I_n \cdot \frac{400}{U'}$$

( $I'_n$  = current at U' Volt);  
( $I'_n$  = intensité à U' Volt);  
( $I'_n$  = Strom mit U' Volt);  
( $I'_n$  = corriente de U' Voltios);  
( $I'_n$  = corrente a U' Volt);

$$\nabla J = \frac{PD^2}{4}$$

<b>GB</b>	<b>Motors driven by inverter</b>	<b>Self-ventilated motor (IC 411)</b>	<b>Pole</b>	<b>GB</b>
<b>F</b>	<b>Moteurs alimentés par inverseur</b>	<b>Moteur autoventilé (IC 411)</b>	<b>Pôles</b>	<b>F</b>
<b>D</b>	<b>Umrichter- Motoren</b>	<b>Eigenbelüfteter Motor (IC 411)</b>	<b>Pole</b>	<b>D</b>
<b>E</b>	<b>Motores para inverter</b>	<b>Motor autoventilado (IC 411)</b>	<b>Polos</b>	<b>E</b>
<b>I</b>	<b>Motori per inverter</b>	<b>Motore autoventilato (IC 411)</b>	<b>Poli</b>	<b>I</b>

	400 V, 50 Hz	[Hz] 5 ÷ 50 range 1 ÷ 10	[Hz] 10 ÷ 50 range 1 ÷ 5	[Hz] 5 ÷ 50 ÷ 87 range 1 ÷ 10 ÷ 17	[Hz] 87 range 17	[Hz] 100 range 20		
Motor type	Mains connection	Quadratic torque	Constant torque	Constant torque	Constant torque	Constant torque	LCIE Certificates	Class T
Moteur type	Alimentation de secteur	Couple quadratique	Couple constant	Couple constant	Couple constant	Couple constant	LCIE Certificat	Classe T
Motor Typ	Netzeinspeisung	Quadratisches Gegenmoment	Konstantes Gegenmoment	Konstantes Gegenmoment	Konstantes Gegenmoment	Konstantes Gegenmoment	LCIE Konformitäts Bescheinigung	Klasse T
Tipo de motor	Alimentación desde la red	Par cuadrático	Par constante	Par constante	Par constante	Par constante	Certificados LCIE	Clase T
Tipo motore	Alimentazione da rete	Coppia quadratica	Coppia costante	Coppia costante	Coppia costante	Coppia costante	Certificati LCIE	Classe T

IIB	IIC	P <sub>n</sub>	I <sub>n</sub>	P <sub>n</sub>	M <sub>n</sub>	P <sub>n</sub>	M <sub>n</sub>	P <sub>n</sub>	M <sub>n</sub>	P <sub>n</sub>	M <sub>n</sub>	P <sub>n</sub>	M <sub>n</sub>	IIB- IIC	
Ex d	Ex d	[kW]	[A]	[kW]	[Nm]	[kW]	[Nm]	[kW]	[Nm]	[kW]	[Nm]	[kW]	[Nm]	Ex d	
Ex de	Ex de													Ex de	

3000 [1/min]														3000 [1/min]		
F 63 BTV A2	<b>F 63 CTV A2</b>	0.12	0.40	0.12	0.40	0.11	0.36	0.08	0.28	0.15	0.28	0.13	0.22	00 ATEX 6036	4	
F 63 BTV A2	<b>F 63 CTV A2</b>	0.18	0.60	0.18	0.60	0.18	0.60	0.18	0.60	0.28	0.54	0.26	0.43	00 ATEX 6036	4	
F 63 BTV A2	<b>F 63 CTV A2</b>	0.25	0.80	0.25	0.80	0.25	0.80	0.25	0.80	0.29	0.56	0.27	0.44	00 ATEX 6036	4	
F 71 BTV B2	<b>F 71 CTV B2</b>	0.37	1.30	0.37	1.30	0.37	1.30	0.37	1.30	0.31	0.60	0.28	0.46	00 ATEX 6036	4	
F 71 BTV C2	<b>F 71 CTV C2</b>	0.55	1.90	0.55	1.90	0.52	1.80	0.50	1.70	0.50	1.00	0.43	0.75	00 ATEX 6036	4	
F 80 BTV A2	<b>F 80 CTV A2</b>	0.55	1.80	0.55	1.80	0.55	1.80	0.55	1.80	0.55	1.10	0.50	0.85	00 ATEX 6037	4	
F 80 BTV A2	<b>F 80 CTV A2</b>	0.75	2.40	0.75	2.40	0.70	1.67	0.60	1.45	0.80	1.45	0.65	1.10	00 ATEX 6037	4	
F 80 BTV B2	<b>F 80 CTV b2</b>	1.10	3.60	1.10	3.60	1.00	3.40	0.92	3.00	1.05	2.00	0.70	1.15	00 ATEX 6037	4	

1500 [1/min]														1500 [1/min]		
F 63 BTV A4	<b>F 63 CTV A4</b>	0.12	0.80	0.12	0.80	0.12	0.80	0.12	0.80	0.20	0.75	0.18	0.60	00 ATEX 6036	4	
F 63 BTV A4	<b>F 63 CTV A4</b>	0.18	1.20	0.18	1.20	0.18	1.20	0.16	1.10	0.23	0.87	0.20	0.66	00 ATEX 6036	4	
F 71 BTV B4	<b>F 71 CTV B4</b>	0.25	1.60	0.25	1.60	0.22	1.50	0.20	1.30	0.35	1.30	0.35	1.10	00 ATEX 6036	4	
F 71 BTV B4	<b>F 71 CTV B4</b>	0.37	2.40	0.37	2.40	0.33	2.15	0.23	1.50	0.43	1.60	0.37	1.20	00 ATEX 6036	4	
F 80 BTV A4	<b>F 80 CTV A4</b>	0.55	3.60	0.55	3.60	0.50	3.24	0.25	1.62	0.63	2.37	0.60	2.00	00 ATEX 6037	4	
F 80 BTV B4	<b>F 80 CTV B4</b>	0.75	5.00	0.75	5.00	0.70	4.75	0.45	3.00	0.81	3.10	0.75	2.50	00 ATEX 6037	4	
F 80 BTV C4	<b>F 80 CTV C4</b>	1.10	7.30	1.10	7.30	0.70	4.60	0.43	2.90	1.61	6.20	1.75	5.80	00 ATEX 6037	4	

<b>GB</b>	Single phase motors	<b>Speed</b>	<b>Rated data at</b>	<b>direct on line start</b>	<b>rpm</b>	<b>GB</b>
<b>F</b>	Moteurs monophasés	<b>Vitesse</b>	<b>Données nominales à</b>	<b>démarrage direct</b>	<b>3000</b>	<b>F</b>
<b>D</b>	Einphasenmotoren	<b>Drehzahl</b>	<b>Betriebsdaten bei</b>	<b>Direkteinschaltung</b>	<b>1500</b>	<b>D</b>
<b>E</b>	Motores monofásico	<b>Velocidad</b>	<b>Datos nominales</b>	<b>arranque directo</b>	<b>1000</b>	<b>E</b>
<b>I</b>	Motori monofase	<b>Velocità</b>	<b>Dati nominali a</b>	<b>avviamento diretto</b>		<b>I</b>

**230 V**  
**50 Hz**

Motor type	Rated output	Speed	Current	Efficiency	Power factor	Torque	Starting current	Starting torque	Maximum torque	Sound pressure	Moment of inertia	Mass	LCIE Certificates	Class T
<i>Motor type</i>	<i>Puissance</i>	<i>Vitesse</i>	<i>Intensité</i>	<i>Rendement</i>	<i>Facteur de puissance</i>	<i>Couple</i>	<i>Intensité démarrage</i>	<i>Couple démarrage</i>	<i>Couple maximal</i>	<i>Pression sonore</i>	<i>Moment d'inertie</i>	<i>Masse</i>	<i>LCIE Certificat</i>	<i>Classe T</i>
Motor Typ	Leistung	Drehzahl	Strom	Wirkungsgrad	Leistungsfaktor	Moment	Anlaufstrom	Anlaufmoment	Kippmoment	Gerauschwerte	Trägheitsmoment	Masse	LCIE Konformitäts-Bescheinigung	Klasse T
<i>Tipo de motor</i>	<i>Potencia proporcionada</i>	<i>Velocidad</i>	<i>Corriente</i>	<i>Rendimiento</i>	<i>Factor de potencia</i>	<i>Par</i>	<i>Corriente de arranque</i>	<i>Par de arranque</i>	<i>Par máximo</i>	<i>Presión acústica</i>	<i>Momento de inercia</i>	<i>Peso</i>	<i>Certificados LCIE</i>	<i>Clase T</i>
Tipo motore	Potenza resa	Velocità	Corrente	Rendimento	Fattore potenza	Coppia	Corrente avviamento	Coppia avviamento	Coppia massima	Pressione sonora	Momento d'inerzia	Massa	Certificato LCIE	Classe T
IIB	IIC	P <sub>n</sub>	n	I <sub>n</sub> *	η	cos φ	M <sub>n</sub>	I <sub>a</sub> /I <sub>n</sub>	M <sub>a</sub> /M <sub>n</sub>	M <sub>m</sub> /M <sub>n</sub>	L <sub>p</sub>	J ▼	m	IIB - IIC
Ex d	Ex d	[kW]	[1/min]	[A]	[%]		[Nm]				[dB(A)]	[kgm <sup>2</sup> ]	[kg]	Ex d
F 56 BM A2♦♦□	F 56 CM A2♦♦□	0.06	2640	0.80	45	0.80	0.20	2.80	1.00	1.10	52	0.0012	4.5	00 ATEX 6035
F 56 BM B2♦♦□	F 56 CM B2♦♦□	0.08	2840	0.90	50	0.86	0.27	3.00	1.10	1.15	52	0.0013	5.0	00 ATEX 6035
F 63 BMV A2	F 63 CMV A2	0.12	2800	1.60	40	0.82	0.41	4.10	3.60	3.80	62	0.0008	8.0	00 ATEX 6036
F 63 BMV B2	F 63 CMV B2	0.18	2865	2.35	49	0.70	0.60	4.60	3.50	3.70	62	0.0010	8.0	00 ATEX 6036
F 63 BMV B2	F 63 CMV B2	0.25	2830	2.60	54	0.77	0.84	4.30	3.20	3.30	62	0.0010	9.5	00 ATEX 6036
F 71 BMV C2	F 71 CMV C2	0.37	2780	3.50	56	0.81	1.27	4.30	2.50	2.70	64	0.0013	10.0	00 ATEX 6036
F 80 BMV B2	F 80 CMV B2	0.55	2930	6.20	62	0.62	1.79	5.50	4.50	5.00	66	0.0016	16.0	00 ATEX 6037
F 80 BMV B2	F 80 CMV B2	0.75	2910	6.80	68	0.72	2.46	5.00	3.30	3.80	66	0.0016	16.0	00 ATEX 6037
F 56 BM A4♦♦□	F 56 CM A4♦♦□	0.06	1410	0.72	44	0.84	0.41	2.70	1.10	1.15	50	0.0012	4.5	00 ATEX 6035
F 56 BM B4♦♦□	F 56 CM B4♦♦□	0.08	1390	0.95	49	0.79	0.56	2.70	1.30	1.35	50	0.0012	5.0	00 ATEX 6035
F 63 BMV B4	F 63 CMV B4	0.12	1415	1.70	47	0.70	0.81	3.50	2.20	2.40	55	0.0012	8.5	00 ATEX 6036
F 63 BMV C4	F 63 CMV C4	0.18	1430	2.10	54	0.68	1.20	3.80	2.20	2.30	55	0.0013	10.0	00 ATEX 6036
F 71 BMV C4	F 71 CMV C4	0.25	1410	3.30	48	0.68	1.69	3.30	1.80	2.00	56	0.0013	10.0	00 ATEX 6036
F 80 BMV A4	F 80 CMV A4	0.25	1460	2.80	61	0.68	1.64	4.30	2.20	2.40	56	0.0024	14.0	00 ATEX 6037
F 80 BMV B4	F 80 CMV B4	0.37	1445	3.40	65	0.74	2.45	4.30	2.20	2.40	56	0.0024	14.0	00 ATEX 6037
F 80 BMV B4	F 80 CMV B4	0.55	1430	5.60	61	0.70	3.67	4.10	2.40	2.60	56	0.0024	14.0	00 ATEX 6037
F 80 BMV C4	F 80 CMV C4	0.75	1390	6.40	66	0.76	5.16	2.80	1.53	1.60	56	0.0030	14.5	00 ATEX 6037
F 63 BMV B6□	F 63 CMV B6□	0.10	950	1.20	39	0.93	1.01	3.00	0.70	0.70	52	0.0012	8.5	00 ATEX 6036
F 63 BMV C6□	F 63 CMV C6□	0.12	925	1.45	41	0.93	1.24	2.50	0.65	0.65	54	0.0013	10.0	00 ATEX 6036
F 71 BMV C6□	F 71 CMV C6□	0.15	935	1.60	44	0.99	1.53	3.50	0.65	0.80	54	0.0013	10.0	00 ATEX 6036
F 80 BMV A6□	F 80 CMV A6□	0.18	965	2.20	47	0.81	1.78	3.00	0.66	0.70	56	0.0024	14.0	00 ATEX 6037
F 80 BMV B6□	F 80 CMV B6□	0.25	950	2.50	51	0.85	2.51	2.60	0.60	0.60	56	0.0024	14.0	00 ATEX 6037
F 80 BMV C6□	F 80 CMV C6□	0.37	945	4.50	62	0.60	3.74	2.90	2.10	2.20	56	0.0030	16.0	00 ATEX 6037

- ♦ Unventilated motors    • Short    ■ Long    □ Permanent capacitor
- Non ventilés            Court       Long       Condensateur permanent
- unbelüftet              Kurz       Lang       Permanent-Kondensator
- No ventilados           Corto      Largo      Condensador permanente
- Non ventilati            Corto      Lungo     Condensatore permanente

\* I<sub>n</sub>' = I<sub>n</sub> ·  $\frac{400}{U'}$  (I<sub>n</sub>' = current at U' Volt);  
(I<sub>n</sub>' = intensité à U' Volt);  
(I<sub>n</sub>' = Strom mit U' Volt);  
(I<sub>n</sub>' = corriente de U' Voltios);  
(I<sub>n</sub>' = corrente a U' Volt);

▼ J =  $\frac{PD^2}{4}$

## **5. Overall dimensions**

- 5.1 Ventilated motors
- 5.2 Unventilated motors
- 5.3 Self-braking motors

## **5. *Dimensions***

- 5.1 *Moteurs ventilés*
- 5.2 *Moteurs non ventilés*
- 5.3 *Moteurs freins*

## **5. Abmessungen**

- 5.1 Motoren belüftet
- 5.2 Motoren unbelüftet
- 5.3 Selbstbremsende Motoren

## **5. *Dimensiones de espacio máximo***

- 5.1 *Motore ventilados*
- 5.2 *Motores no ventilados*
- 5.3 *Motores con freno*

## **5. Dimensioni d'ingombro**

- 5.1 Motori ventilati
- 5.2 Motori non ventilati
- 5.3 Motori autofrenanti

IM B3

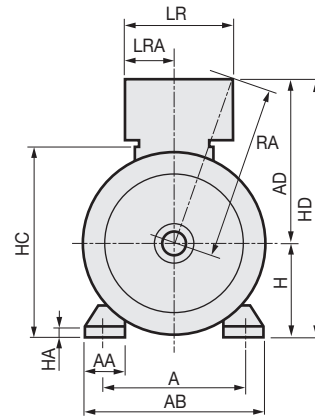
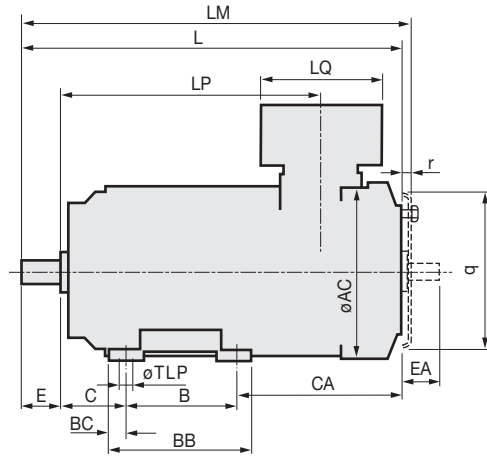

IM B5

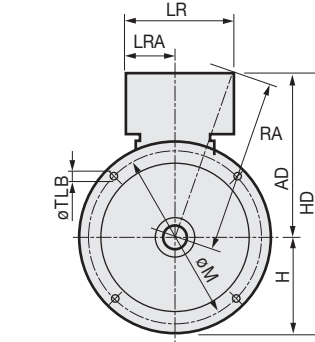
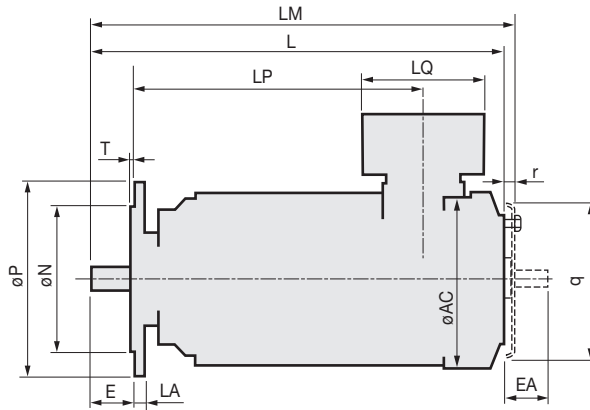

IM B35

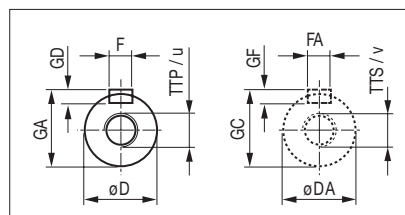
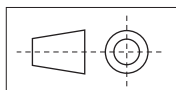
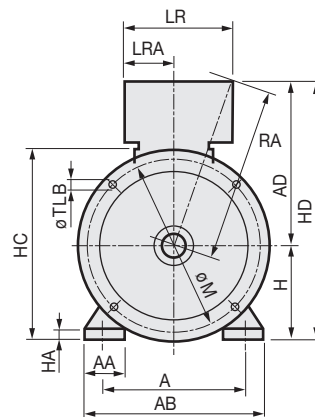
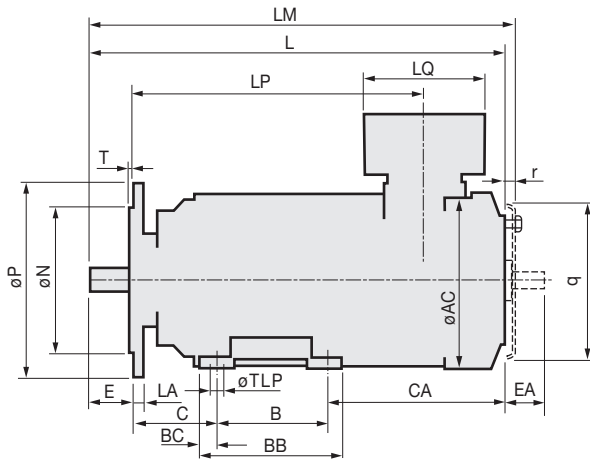

## Overall dimensions [mm]

GB

## Dimensions [mm]

F

## Abmessungen [mm]

D

## Dimensiones [mm]

E

## Dimensioni d'ingombro [mm]

I

## Structure - Structure - Gehäuse - Estructura - Struttura

Type	A	AA	AB	ø AC	B	BB	BC	C	CA	E EA	H	HA	HC	L	LM	LP	ø q	r	ø TLP
<b>63 B3</b>	100	30	126	132	80	100	10	40	141	23	63	5	135	284	307	173	118	23	7
<b>63 B5 B35</b>	100	30	126	132	80	100	10	55	141	23	63	5	135	299	322	188	118	23	7
<b>71 B3</b>	112	36	138	132	90	110	10	45	126	30	71	6	143	291	314	173	118	23	7
<b>71 B5 B35</b>	112	36	138	132	90	110	10	60	126	30	71	6	143	306	329	188	118	23	7
<b>80 B3</b>	125	35	155	162	100	124	12	50	126	40	80	8	165	316	339	202	146	23	9
<b>80 B5 B35</b>	125	35	155	162	100	124	12	70	126	40	80	8	165	336	359	222	146	23	9

## Terminal box - Boîte à bornes - Klemmkasten - Caja de bornes - Morsettiera

Ex d ① Type	AD	HD	LQ	LR	RA	LRA
<b>63 B3</b>	164	227	144	144	174	68
<b>63 B5 B35</b>	164	227	144	144	174	68
<b>71 B3</b>	164	235	144	144	174	68
<b>71 B5 B35</b>	164	235	144	144	174	68
<b>80 B3</b>	175	255	144	144	184	68
<b>80 B5 B35</b>	175	255	144	144	184	68

Ex d ③ Type	AD	HD	LQ	LR	RA	LRA
<b>63 B3</b>	153	216	108	108	160	50
<b>63 B5 B35</b>	153	216	108	108	160	50
<b>71 B3</b>	153	224	108	108	160	50
<b>71 B5 B35</b>	153	224	108	108	160	50
<b>80 B3</b>	166	246	108	108	172	50
<b>80 B5 B35</b>	166	246	108	108	172	50

Ex de ③ Type	AD		HD		LQ		LR		RA		LRA	
	Standard	VIK	Standard	VIK	Standard	VIK	Standard	VIK	Standard	VIK	Standard	VIK
<b>63 B3</b>	174	192	237	255	145	190	120	175	182	210	60	86
<b>63 B5 B35</b>	174	192	237	255	145	190	120	175	182	210	60	86
<b>71 B3</b>	174	192	245	263	145	190	120	175	182	210	60	86
<b>71 B5 B35</b>	174	192	245	263	145	190	120	175	182	210	60	86
<b>80 B3</b>	187	205	267	285	145	190	120	175	193	233	60	86
<b>80 B5 B35</b>	187	205	267	285	145	190	120	175	193	233	60	86

## Shaft - Arbre - Welle - Eje - Albero

Type	ø D	F	GA	GD	ø TTP	u
	ø D <sub>max</sub>	FA	GC	GF	ø TTS	v
<b>63 B3</b>	11	4	12.5	4	M4	10
<b>63 B5 B35</b>	11	4	12.5	4	M4	10
<b>71 B3</b>	14	5	16.0	5	M5	12
<b>71 B5 B35</b>	14	5	16.0	5	M5	12
<b>80 B3</b>	19	6	21.5	6	M6	15
<b>80 B5 B35</b>	19	6	21.5	6	M6	15

## Flanges - Brides - Flansch - Bidas - Flange

Type	LA	ø M	ø N	ø P	T	ø TLB
<b>63 B5 B35</b>	8	115	95	140	3.0	9
<b>71 B5 B35</b>	8	130	110	160	3.5	9
<b>80 B5 B35</b>	10	165	130	200	3.5	11

①  
Single phase  
Monophasés  
Einphasen  
Monofásico  
Monofase

③  
Three phase  
Triphasés  
Drehstrom  
Trifásico  
Trifase

LR:  
Without cable gland  
Sans presse étoupe  
Ohne Kabelpresse  
Sin prensacables  
Senza pressacavo

VIK:  
Specifications  
Spécifications  
Spezifikationen  
Especificaciones  
Specifiche

IM B14

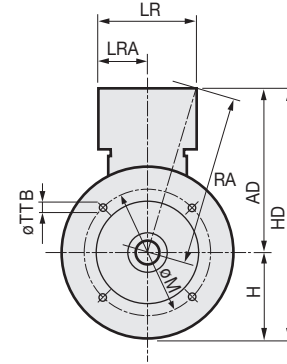
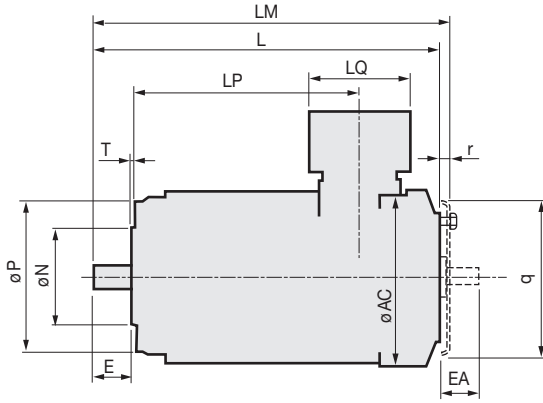

IM B34

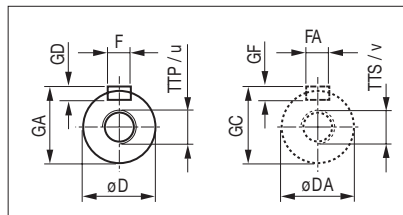
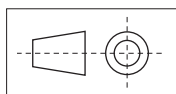
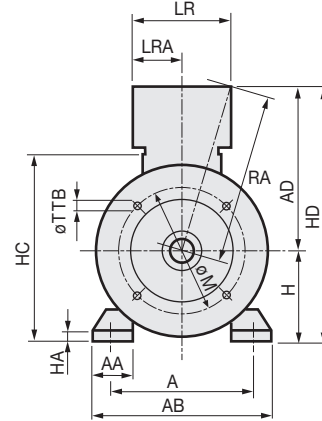
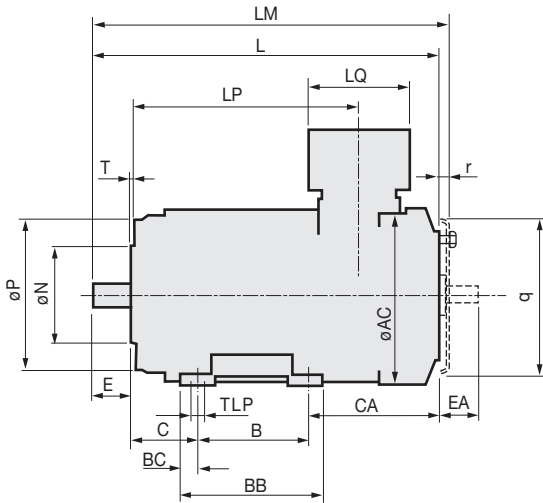



## Overall dimensions [mm]

## Dimensions [mm]

## Abmessungen [mm]

## Dimensiones [mm]

## Dimensioni d'ingombro [mm]

## Structure - Structure - Gehäuse - Estructura - Struttura

Type	A	AA	AB	∅ AC	B	BB	BC	C	CA	E EA	H	HA	HC	L	LM	LP	∅ q	r	∅ TLP
63 B14 B34	100	30	126	132	80	100	10	40	141	23	63	5	135	284	307	173	118	23	7
71 B14 B34	112	36	138	132	90	110	10	45	126	30	71	6	143	291	314	173	118	23	7
80 B14 B34	125	35	155	162	100	124	12	50	126	40	80	8	165	316	339	202	146	23	9

## Terminal box - Boîte à bornes - Klemmkasten - Caja de bornes - Morsettiera

Ex d ① Type	AD	HD	LQ	LR	RA	LRA
63 B14 B34	164	227	144	144	174	68
71 B14 B34	164	235	144	144	174	68
80 B14 B34	175	255	144	144	184	68

Ex d ③ Type	AD	HD	LQ	LR	RA	LRA
63 B14 B34	153	216	108	108	160	50
71 B14 B34	153	224	108	108	160	50
80 B14 B34	166	246	108	108	172	50

Ex de ③ Type	AD		HD		LQ		LR		RA		LRA	
	Standard	VIK	Standard	VIK	Standard	VIK	Standard	VIK	Standard	VIK	Standard	VIK
63 B14 B34	174	192	237	255	145	190	120	175	182	210	60	86
71 B14 B34	174	192	245	263	145	190	120	175	182	210	60	86
80 B14 B34	187	205	267	285	145	190	120	175	182	233	60	86

## Shaft - Arbre - Welle - Eje - Albero

Type	∅ D	F	GA	GD	∅ TTP	u
	∅ D <sub>Amax</sub>	FA	GC	GF	∅ TTS	v
63 B14 B34	11	4	12.5	4	M4	10
71 B14 B34	14	5	16.0	5	M5	12
80 B14 B34	19	6	21.5	6	M6	15

## Flanges - Brides - Flansch - Bidas - Flange

Type	∅ M	∅ N	∅ P	T	∅ TTB
63 B14 B34	75	60	90	2.5	M5
71 B14 B34	85	70	105	2.5	M6
80 B14 B34	100	80	120	3.0	M6

①  
Single phase  
Monophasés  
Einphasen  
Monofásico  
Monofase

③  
Three phase  
Triphasés  
Drehstrom  
Trifásico  
Trifase

LR:  
Without cable gland  
Sans presse étoupe  
Ohne Kabelpresse  
Sin prensacables  
Senza pressacavo

VIK:  
Specifications  
Spécifications  
Spezifikationen  
Especificaciones  
Specifiche

PADS  
BOSSAGES  
BESCHLÄGE  
ABOLLADORAS  
BORCHIE

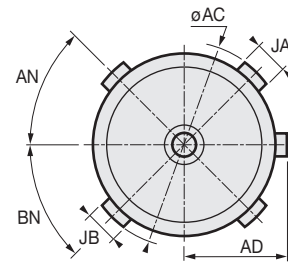
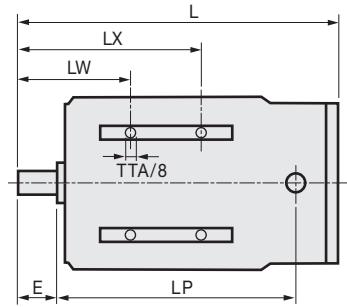

IM B3

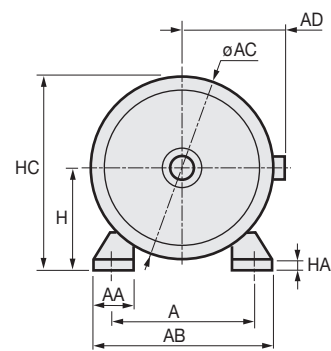
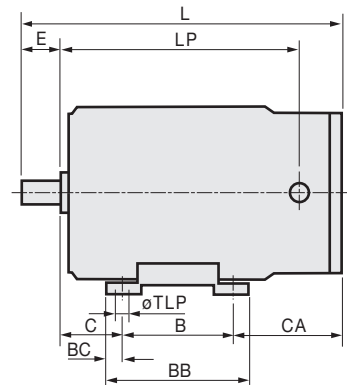

IM B5

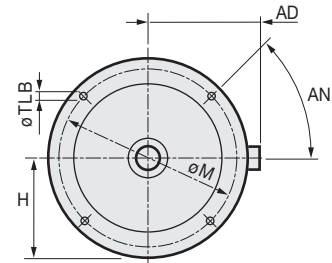
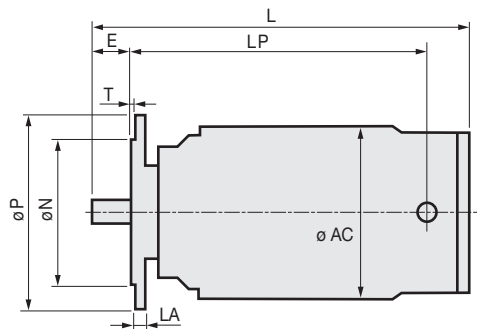

IM B35

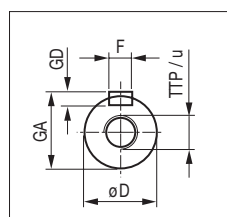
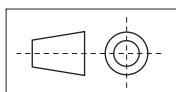
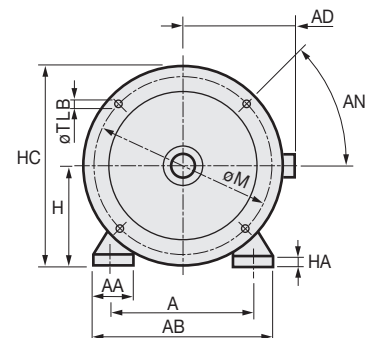
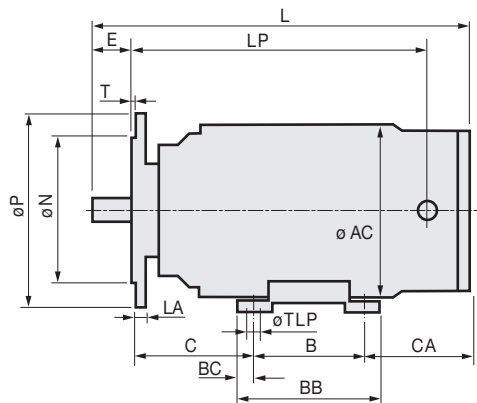

## Overall dimensions [mm]

GB

## Dimensions [mm]

F

## Abmessungen [mm]

D

## Dimensiones [mm]

E

## Dimensioni d'ingombro [mm]

I

## Structure - Structure - Gehäuse - Estructura - Struttura

Type	A	AA	AB	∅ AC	AD	AN	BN	B	BB	BC	C	CA	E
56 B3 - 56 ▲	90	---	110	108	85	45°	45°	71	95	12	36	46	20
56 B5 - 56 B35	90	---	110	108	85	45°	---	71	95	12	36	46	20
63 B3 - 63 ▲	100	30	126	132	74	45°	45°	80	100	10	40	105	23
63 B5 - 63 B35	100	30	126	132	74	45°	---	80	100	10	55	105	23
71 B3 - 71 ▲	112	36	138	132	74	45°	45°	90	110	10	45	90	30
71 B5 - 71 B35	112	36	138	132	74	45°	---	90	110	10	60	90	30
80 B3 - 80 ▲	125	35	155	162	112	45°	45°	100	124	12	50	108	40
80 B5 - 80 B35	125	35	155	162	112	45°	---	100	124	12	70	108	40

Type	H	HA	HC	JA	JB	L		LP		LW	LX	∅ TLP	TTA
						●	■	●	■				
56 B3 - 56 ▲	56	3	113	7	7	212	232	155	175	65	105	6	M5
56 B5 - 56 B35	56	3	113	---	---	222	242	165	185	---	---	6	---
63 B3 - 63 ▲	63	5	129	15	21	248	---	200	---	94	132	7	M6
63 B5 - 63 B35	63	5	129	---	---	263	---	215	---	---	---	7	---
71 B3 - 71 ▲	71	6	137	15	21	255	---	200	---	101	139	7	M6
71 B5 - 71 B35	71	6	137	---	---	270	---	215	---	---	---	7	---
80 B3 - 80 ▲	80	8	163	15	21	298	---	214	---	118	162	9	M6
80 B5 - 80 B35	80	8	163	---	---	318	---	234	---	---	---	9	---

## Shaft - Arbre - Welle - Eje - Albero

Type	∅ D	F	GA	GD	∅ TTP	u
56 B3 - 56 ▲	9	3	10.2	3	M3	9
56 B5 - 56 B35	9	3	10.2	3	M3	9
63 B3 - 63 ▲	11	4	12.5	4	M4	10
63 B5 - 63 B35	11	4	12.5	4	M4	10
71 B3 - 71 ▲	14	5	16.0	5	M5	12
71 B5 - 71 B35	14	5	16.0	5	M5	12
80 B3 - 80 ▲	19	6	21.5	6	M6	15
80 B5 - 80 B35	19	6	21.5	6	M6	15

## Flanges - Brides - Flansch - Bidas - Flange

Type	LA	∅ M	∅ N	∅ P	T	∅ TLB
56 B5 B35	7	100	80	120	3.0	7
63 B5 B35	8	115	95	140	3.0	9
71 B5 B35	8	130	110	160	3.5	9
80 B5 B35	10	165	130	200	3.5	11

AD =

With cable gland  
Avec presse-étoupe  
Mit Kabelpresse  
Con prensacables  
Con pressacavo

●

Short  
Court  
Kurz  
Corto  
Corto

■

Long  
Long  
Lang  
Largo  
Lungo

▲ =

Pads  
Bossages  
Beschlüge  
Abolladoras  
Borchie

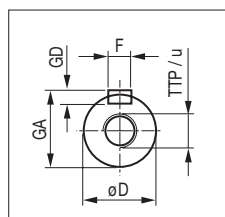
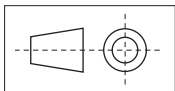
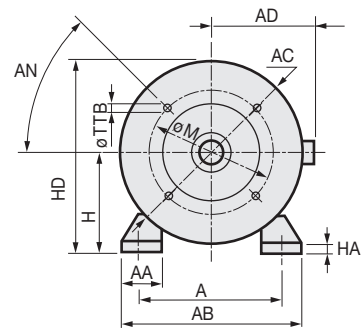
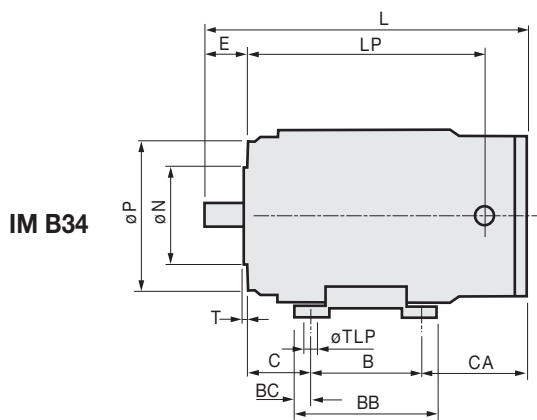
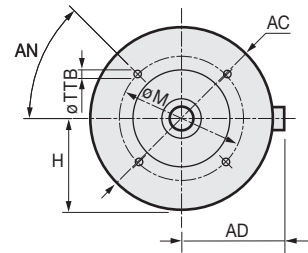
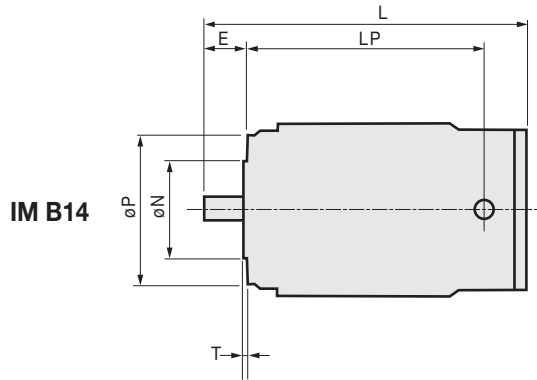

## Overall dimensions [mm]

GB

## Dimensions [mm]

F

## Abmessungen [mm]

D

## Dimensiones [mm]

E

## Dimensioni d'ingombro [mm]

I

## Structure - Structure - Gehäuse - Estructura - Struttura

Type	A	AA	AB	∅ AC	AD	AN	BN	B	BB	BC	C	CA	E
56 B14 B34	90	---	110	108	85	45°	45°	71	95	12	36	46	20
63 B14 B34	100	30	126	132	74	45°	45°	80	100	10	40	105	23
71 B14 B34	112	36	138	132	74	45°	45°	90	110	10	45	90	30
80 B14 B34	125	35	155	162	112	45°	45°	100	124	12	50	108	40

Type	H	HA	HC	JA	JB	L		LP		LW	LX	∅ TLP
						●	■	●	■			
56 B14 B34	56	3	113	7	7	207	227	150	170	---	---	6
63 B14 B34	63	5	129	15	21	248	---	200	---	---	---	7
71 B14 B34	71	6	137	15	21	255	---	200	---	---	---	7
80 B14 B34	80	8	163	15	21	298	---	214	---	---	---	9

## Shaft - Arbre - Welle - Eje - Albero

Type	∅ D	F	GA	GD	∅ TTP	u
56 B14 B34	9	3	10.2	3	M3	9
63 B14 B34	11	4	12.5	4	M4	10
71 B14 B34	14	5	16.0	5	M5	12
80 B14 B34	19	6	21.5	6	M6	15

## Flanges - Brides - Flansch - Bidas - Flange

Type	∅ M	∅ N	∅ P	T	∅ TTb
56 B14 B34	65	50	85	2.5	M5
63 B14 B34	75	60	90	2.5	M5
71 B14 B34	85	70	105	2.5	M6
80 B14 B34	100	80	120	3.0	M6

AD =

With cable gland  
Avec presse-étoupe  
Mit Kabelpresse  
Con prensacables  
Con pressacavo

●

Short  
Court  
Kurz  
Corto  
Corto

■

Long  
Long  
Lang  
Largo  
Lungo

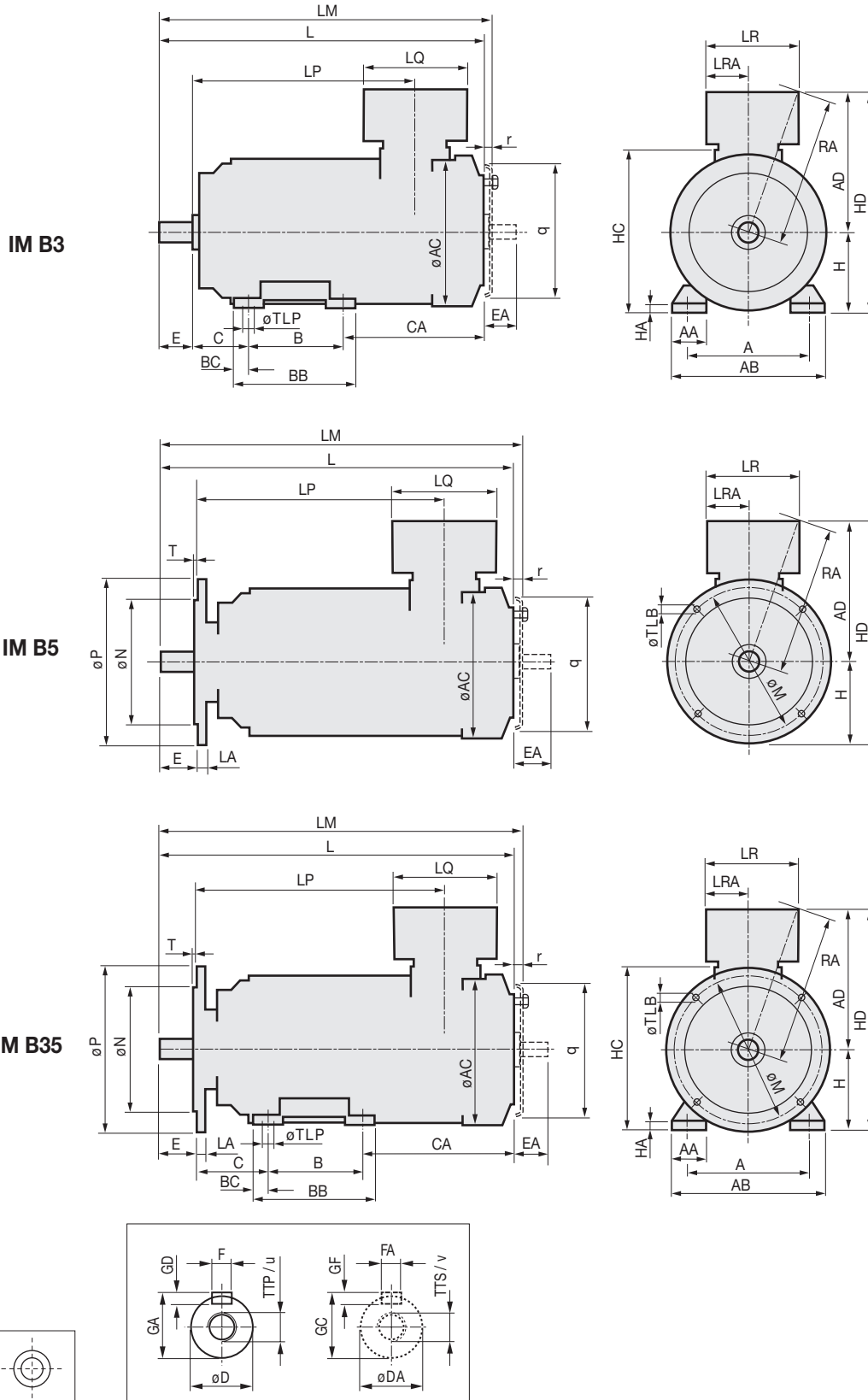

## Overall dimensions [mm]

## Dimensions [mm]

## Abmessungen [mm]

## Dimensiones [mm]

## Dimensioni d'ingombro [mm]

## Structure - Structure - Gehäuse - Estructura - Struttura

Type	A	AA	AB	ø AC	B	BB	BC	C	CA		E EA	H	HA	HC	L		LM	
									◆	▲					◆	▲	◆	▲
63 B3	100	30	126	132	80	100	10	40	165	189	23	63	5	135	309	333	332	356
63 B5 B35	100	30	126	132	80	100	10	55	165	189	23	63	5	135	324	348	347	371
71 B3	112	36	138	132	90	110	10	45	150	174	30	71	6	143	316	340	339	363
71 B5 B35	112	36	138	132	90	110	10	60	150	174	30	71	6	143	331	355	354	378
80 B3	125	35	155	162	100	124	12	50	176	196	40	80	8	165	366	386	389	409
80 B5 B35	125	35	155	162	100	124	12	70	176	196	40	80	8	165	386	406	409	429

Type	LP		ø q	r	ø TLP
	◆	▲			
63 B3	197	221	118	23	7
63 B5 B35	212	236	118	23	7
71 B3	197	221	118	23	7
71 B5 B35	212	236	118	23	7
80 B3	252	272	146	23	9
80 B5 B35	272	292	146	23	9

## Terminal box - Boîte à bornes - Klemmkasten - Caja de bornes - Morsettiera

Type	AD	HD	LQ	LR	RA	LRA
63 B3	164	227	144	144	174	68
63 B5 B35	164	227	144	144	174	68
71 B3	164	235	144	144	174	68
71 B5 B35	164	235	144	144	174	68
80 B3	175	255	144	144	184	68
80 B5 B35	175	255	144	144	184	68

## Shaft - Arbre - Welle - Eje - Albero

Type	ø D	F	GA	GD	ø TTP	u
	ø D <sub>max</sub>	FA	GC	GF	ø TTS	v
63 B3	11	4	12.5	4	M4	10
63 B5 B35	11	4	12.5	4	M4	10
71 B3	14	5	16.0	5	M5	12
71 B5 B35	14	5	16.0	5	M5	12
80 B3	19	6	21.5	6	M6	15
80 B5 B35	19	6	21.5	6	M6	15

## Flanges - Brides - Flansch - Bidas - Flange

Type	LA	ø M	ø N	ø P	T	ø TLB
63 B5 B35	8	115	95	140	3.0	9
71 B5 B35	8	130	110	160	3.5	9
80 B5 B35	10	165	130	200	3.5	11

◆	Frame size	Pole	Power
	<i>Hauteur d'axe</i>	<i>Pôles</i>	<i>Puissance</i>
	<i>Größe</i>	<i>Polig</i>	<i>Leistung</i>
	<i>Tamaño</i>	<i>Polos</i>	<i>Potencia</i>
	<i>Altezza d'asse</i>	<i>Poli</i>	<i>Potenza</i>

63/71	2; 4	≤ 0.18 [kW]
80	2; 4	≤ 0.75 [kW]
	6	≤ 0.37 [kW]
	8	≤ 0.25 [kW]

▲	Frame size	Pole	Power
	<i>Hauteur d'axe</i>	<i>Pôles</i>	<i>Puissance</i>
	<i>Größe</i>	<i>Polig</i>	<i>Leistung</i>
	<i>Tamaño</i>	<i>Polos</i>	<i>Potencia</i>
	<i>Altezza d'asse</i>	<i>Poli</i>	<i>Potenza</i>

63/71	2; 4	> 0.18 [kW]
	6; 8	> 0.075 [kW]
80	2; 4	> 0.75 [kW]
	6	> 0.37 [kW]
	8	> 0.25 [kW]

IM B14

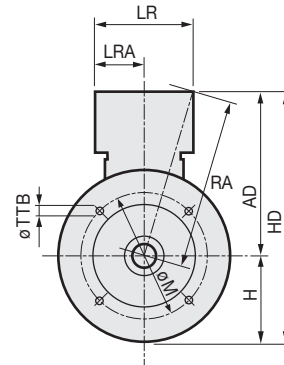
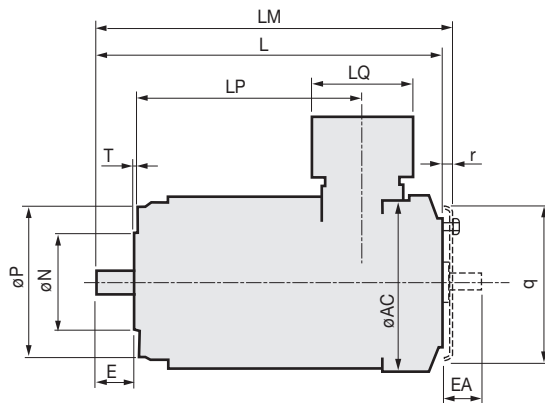

IM B34

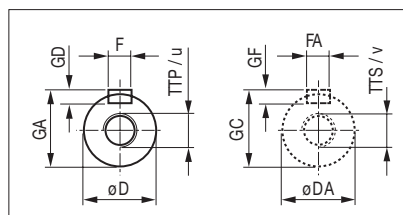
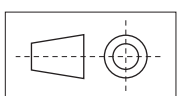
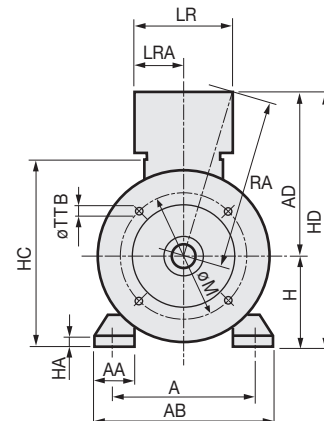
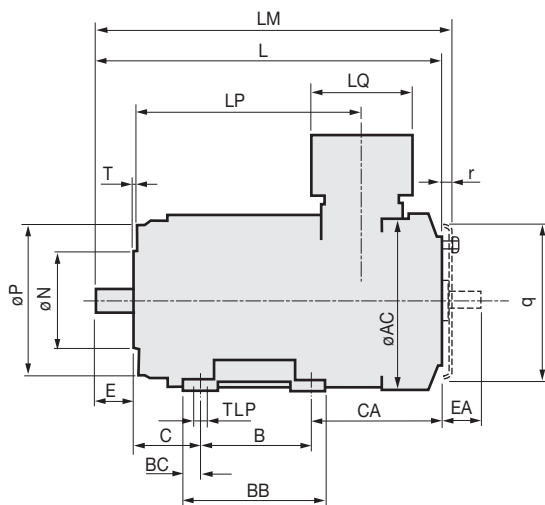



## Overall dimensions [mm]

## Dimensions [mm]

## Abmessungen [mm]

## Dimensiones [mm]

## Dimensioni d'ingombro [mm]

Structure - Structure - Gehäuse - Estructura - Struttura

Type	A	AA	AB	ø AC	B	BB	BC	C	CA		E EA	H	HA	HC	L		LM	
									◆	▲					◆	▲	◆	▲
63 B14 B34	100	30	126	132	80	100	10	40	165	189	23	63	5	135	309	333	332	356
71 B14 B34	112	36	138	132	90	110	10	45	150	174	30	71	6	143	316	340	347	371
80 B14 B34	125	35	155	162	100	124	12	50	176	196	40	80	8	165	366	386	389	409

Type	LP		ø q	r	ø TLP
	◆	▲			
63 B14 B34	197	221	118	23	7
71 B14 B34	197	221	118	23	7
80 B14 B34	252	272	146	23	9

Terminal box - Boîte à bornes - Klemmkasten - Caja de bornes - Morsettiera

Type	AD	HD	LQ	LR	RA	LRA
63 B14 B34	164	227	144	144	174	68
71 B14 B34	164	235	144	144	174	68
80 B14 B34	175	255	144	144	184	68

Shaft - Arbre - Welle - Eje - Albero

Type	ø D	F	GA	GD	ø TTP	u
	ø D <sub>Amax</sub>	FA	GC	GF	ø TTS	v
63 B14 B34	11	4	12.5	4	M4	10
71 B14 B34	14	5	16.0	5	M5	12
80 B14 B34	19	6	21.5	6	M6	15

Flanges - Brides - Flansch - Bidas - Flange

Type	ø M	ø N	ø P	T	ø TTB
63 B14 B34	75	60	90	2.5	M5
71 B14 B34	85	70	105	2.5	M6
80 B14 B34	100	80	120	3.0	M6

◆	Frame size	Pole	Power
	<i>Hauteur d'axe</i>	<i>Pôles</i>	<i>Puissance</i>
	<i>Größe</i>	<i>Polig</i>	<i>Leistung</i>
	<i>Tamaño</i>	<i>Polos</i>	<i>Potencia</i>
	<i>Altezza d'asse</i>	<i>Poli</i>	<i>Potenza</i>

63/71 2; 4 ≤ 0.18 [kW]

80 2; 4 ≤ 0.75 [kW]  
6 ≤ 0.37 [kW]  
8 ≤ 0.25 [kW]

▲	Frame size	Pole	Power
	<i>Hauteur d'axe</i>	<i>Pôles</i>	<i>Puissance</i>
	<i>Größe</i>	<i>Polig</i>	<i>Leistung</i>
	<i>Tamaño</i>	<i>Polos</i>	<i>Potencia</i>
	<i>Altezza d'asse</i>	<i>Poli</i>	<i>Potenza</i>

63/71 2; 4 > 0.18 [kW]  
6; 8 > 0.075 [kW]80 2; 4 > 0.75 [kW]  
6 > 0.37 [kW]  
8 > 0.25 [kW]

## **6. Spare parts**

- 6.1 Spare parts for ventilated three-phase motors
- 6.2 Spare parts for unventilated three-phase motors

## **6. Pièces détachées**

- 6.1 *Pièces détachées moteurs triphasés ventilés*
- 6.2 *Pièces détachées moteurs triphasés non ventilés*

## **6. Ersatzteilliste**

- 6.1 Ersatzteile für Drehstrommotoren belüftet
- 6.2 Ersatzteile für Drehstrommotoren unbelüftet

## **6. Piezas de repuesto**

- 6.1 *Piezas de repuesto motores trifásicos ventilados*
- 6.2 *Piezas de repuesto motores trifásicos no ventilados*

## **6. Parti di ricambio**

- 6.1 Parti di ricambio motori trifase ventilati
- 6.2 Parti di ricambio motori trifase non ventilati

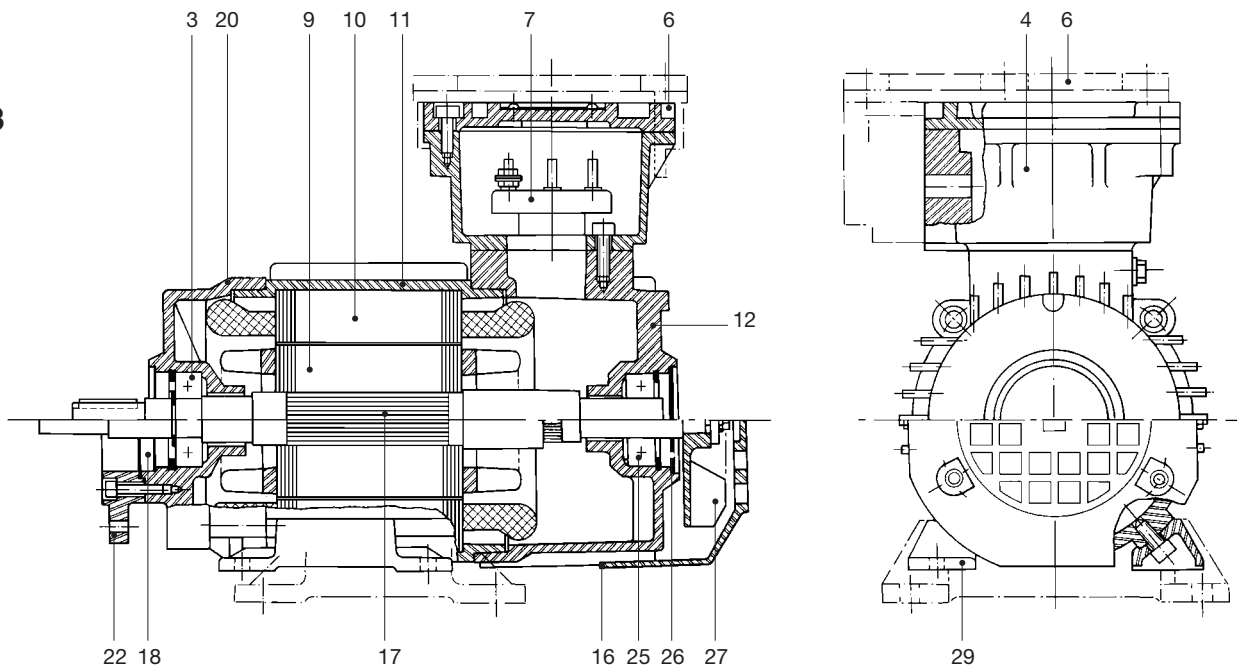
F63  
F71

F80

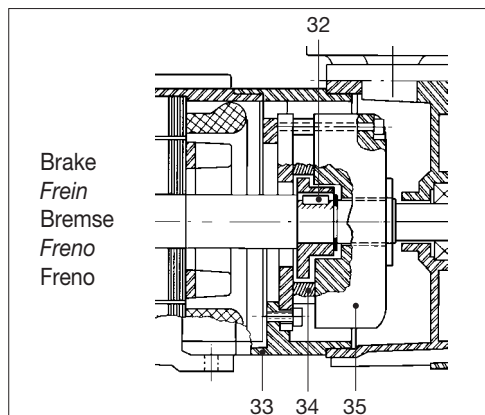
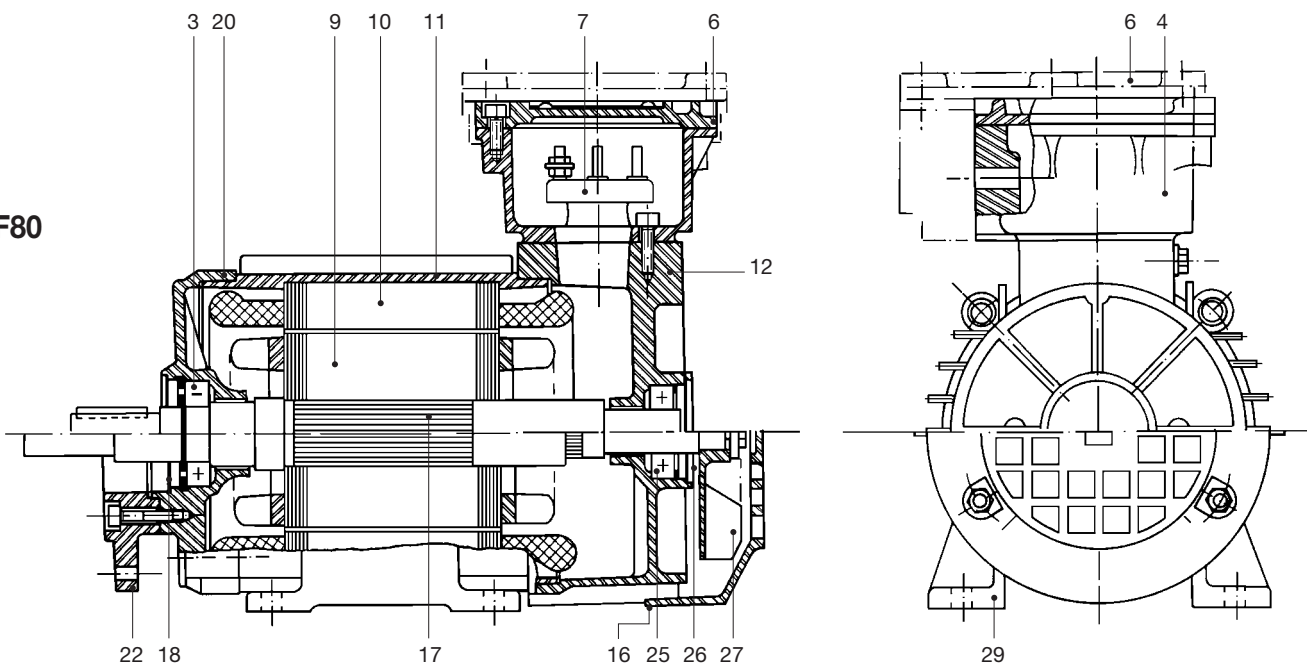

## GB

3 Bearing, driving end,	16 Fan cover	29 Feet/Sliding block
4 Terminal box	17 Shaft	(32) Brake feather key
6 Terminal box cover	18 Dust seal, driving end	(33) Spacer-rim
7 Terminal holder plate	20 Endshield, driving end	(34) Brake disk
9 Rotor	22 Flange insert	(35) Brake
10 Stator	25 Bearing, non-driving end	
11 Frame	26 Dust seal, non driving-end	
12 Endshield, non-driving end	27 Fan	

## F

3 Roulement avant	16 Capot de ventilateur	29 Patin
4 Boîte à bornes	17 Arbre	(32) Clavette de frein
6 Couvercle boîte à bornes	18 Bague avant d'étanchéité	(33) Couronne-entretoise
7 Plaque a bornes	20 Flasque avant	(34) Garniture de frein
9 Rotor	22 Bride rapportée	(35) Frein
10 Stator	25 Roulement arrière	
11 Carcasse	26 Bague arrière d'étanchéité	
12 Flasque arrière	27 Ventilateur	

## D

3 Kugellager A-Seite	16 Lüfterhaube	29 Motorfuß
4 Klemmbrett	17 Welle	(32) Bremskeil
6 Klemmkastendeckel	18 Dichtring A-Seite	(33) Kranz-Distanzstück
7 Klemmkastenplatte	20 Lagerschild A-Seite	(34) Bremsdichtung
9 Rotor	22 Flansch Antriebsseite	(35) Bremse
10 Stator	25 Kugellager B-Seite	
11 Motorgehäuse	26 Dichtring B-Seite	
12 Lagerschild B-Seite	27 Lüfterrad	

## E

3 Cojinete delantero	16 Casquete cubre ventilador	29 Pies
4 Caja de bornes	17 Eje	(32) Lengüeta del freno
6 Cubierta caja de bornes	18 Anillo de retención delantero.	(33) Corona-distancial
7 Placa porta bornes	20 Escudo delantero	(34) Junta de frenado
9 Rotor	22 Brida de acoplamiento	(35) Freno
10 Estator	25 Cojinete trasero	
11 Armazón	26 Anillo de retención trasero.	
12 Escudo trasero	27 Ventilador	

## I

3 Cuscinetto anteriore	16 Calotta copriventola	29 Piede/Piastra d'appoggio
4 Morsettiera	17 Albero	(32) Linguetta del freno
6 Coprimorsettiera	18 Anello di tenuta anteriore	(33) Corona-distanziale
7 Piastra porta morsetti	20 Scudo anteriore	(34) Guarnizione frenante
9 Rotore	22 Flangia riportata	(35) Freno
10 Statore	25 Cuscinetto posteriore	
11 Carcassa	26 Anello di tenuta posteriore	
12 Scudo posteriore	27 Ventola	

F56

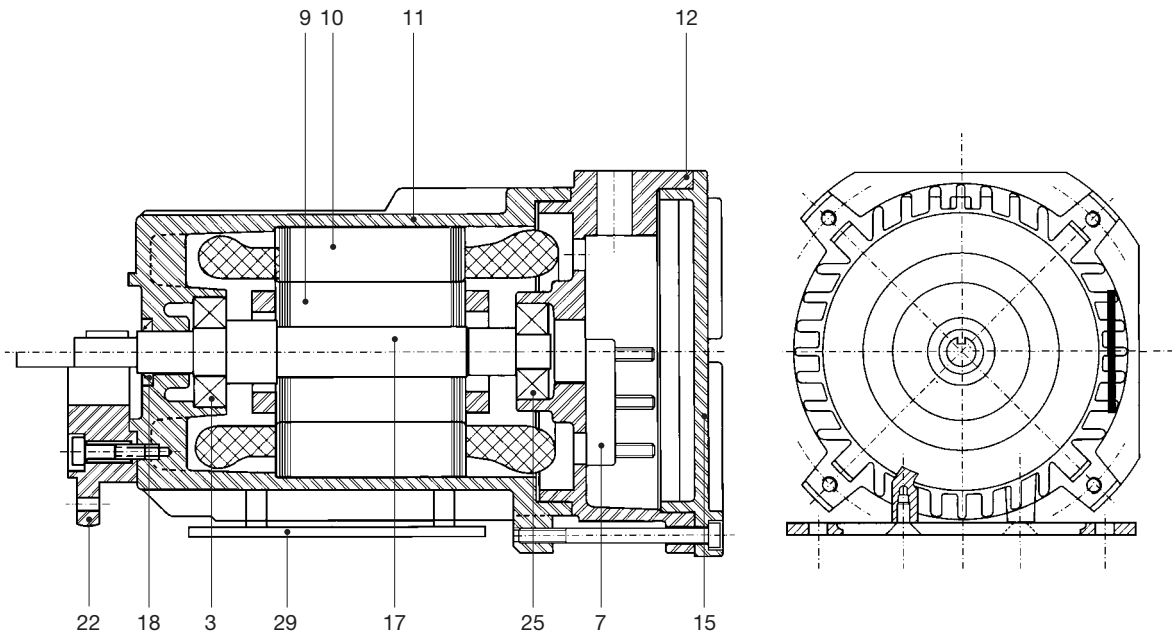

F63

F71

F80

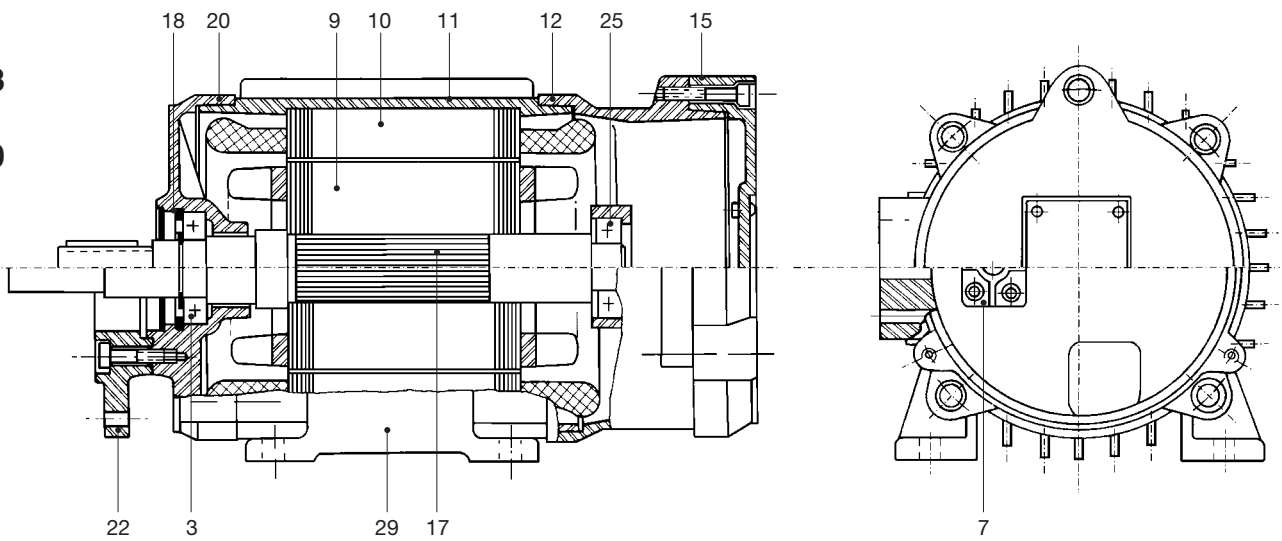

**GB**

- |                               |                             |
|-------------------------------|-----------------------------|
| 3 Bearing, driving end,       | 18 Dust seal, driving end   |
| 7 Terminal holder plate       | 20 Endshield, driving end   |
| 9 Rotor                       | 22 Flange insert            |
| 10 Stator                     | 25 Bearing, non-driving end |
| 11 Frame                      | 29 Sliding block            |
| 12 Endshield, non-driving end |                             |
| 15 Rear outside cover         |                             |
| 17 Shaft                      |                             |

**F**

- |                             |                                    |
|-----------------------------|------------------------------------|
| 3 <i>Roulement avant</i>    | 18 <i>Bague avant d'étanchéité</i> |
| 7 <i>Plaque a bornes</i>    | 20 <i>Flasque avant</i>            |
| 9 <i>Rotor</i>              | 22 <i>Bride rapportée</i>          |
| 10 <i>Stator</i>            | 25 <i>Roulement arrière</i>        |
| 11 <i>Carcasse</i>          | 29 <i>Patin</i>                    |
| 12 <i>Flasque arrière</i>   |                                    |
| 15 <i>Couvercle arrière</i> |                                    |
| 17 <i>Arbre</i>             |                                    |

**D**

- |                         |                          |
|-------------------------|--------------------------|
| 3 Kugellager A-Seite    | 18 Dichtring A-Seite     |
| 7 Klemmbrett            | 20 Lagerschild A-Seite   |
| 9 Rotor                 | 22 Flansch Antriebsseite |
| 10 Stator               | 25 Kugellager B-Seite    |
| 11 Motorgehäuse         | 29 Motorfuß              |
| 12 Lagerschild B-Seite  |                          |
| 15 Anschlußkastendeckel |                          |
| 17 Welle                |                          |

**E**

- |                                     |   |
|-------------------------------------|---|
| 3 <i>Cojinete delantero</i>         | 18 <i>Anillo de retención delantero</i> |
| 7 <i>Placa porta bornes</i>         | 20 <i>Escudo delantero</i>              |
| 9 <i>Rotor</i>                      | 22 <i>Brida de acoplamiento</i>         |
| 10 <i>Estator</i>                   | 25 <i>Cojinete trasero</i>              |
| 11 <i>Armazón</i>                   | 29 <i>Pies</i>                          |
| 12 <i>Escudo trasero</i>            |   |
| 15 <i>Casquillo externo trasero</i> |   |
| 17 <i>Eje</i>                       |   |

**I**

- |                                |                               |
|--------------------------------|-------------------------------|
| 3 Cuscinetto anteriore         | 18 Anello di tenuta anteriore |
| 7 Piastra porta morsetti       | 20 Scudo anteriore            |
| 9 Rotore                       | 22 Flangia riportata          |
| 10 Statore                     | 25 Cuscinetto posteriore      |
| 11 Carcassa                    | 29 Piede/Piastra d'appoggio   |
| 12 Scudo posteriore            |                               |
| 15 Fondello esterno posteriore |                               |
| 17 Albero                      |                               |



**KOLMERELEKTROMOTOREN B.V.**

Uw vaste kracht voor flexibel vermogen

**TD 310**